

Bell 206L4

Bell
Helicopter
A Textron Company



SPECIFICATIONS



PRODUCT SPECIFICATIONS
JANUARY 2006

For additional information visit the Bell Helicopter Textron Website

Homepage: www.bellhelicopter.com

BELL HELICOPTER TEXTRON INC.

Sales Contact Telephone Numbers

Sales Inquiries

U.S. Toll Free: 1-800-FLY-BELL

International/US: 817-280-2800

Email: marketing@bellhelicopter.textron.com

Regional Sales Areas

US/Canada 817-280-6789

Asia Pacific 817-280-2197

Europe/Middle East/Africa 817-280-3261

Latin America 817-280-2879

Used Helicopter Sales / www.BellNetX.com 817-280-2147

Fax: 817-280-8802

Customer Center

Ft. Worth / Alliance Airport Facility

P. O. Box 482

Ft. Worth, TX 76101-0482

817-280-6187 Fax: 817-280-8802

marketing@bellhelicopter.textron.com

Manufacturing Facility

Bell Helicopter Textron Canada Limited

12,800 rue de l'Avenir

Mirabel, Quebec

Canada J7J 1R4

450-437-3400 Fax: 450-437-2006

This book was produced by



Visual Communications Center

P. O. Box 482

Ft. Worth, TX 76101-0482



PUBLISHERS NOTICE

The data presented in this document is general in nature, and has been compiled from Bell Helicopter Textron, Inc. [BHTI] source materials including but not limited to; The Approved Rotorcraft Flight Manual, Maintenance Manual, Illustrated Parts Catalog, and other engineering design specifications.

This document is intended for the use of **BHTI Sales Personnel** and for **prospective customers** as an aid in determining estimated weight and performance of the helicopter when configured with equipment for specific missions.

Disclosure, reproduction, or use of any material in this document by persons other than BHTI employees, and BHTI independent representatives [International Dealers] is **forbidden** without written permission from Bell Helicopter Textron.

The listings of Optional Equipment [KITS] are subject to revision and change, and also may be different for specific serial number helicopters or special custom configurations. Please consult the *NOTES* found in the right margins of the optional equipment list pages for **equipment compatibility**. The continuing product improvement process of BHTI may cause some components, equipment, and compatibility to be changed or replaced.

The SPECIFICATIONS, WEIGHTS, DIMENSIONS, AND PERFORMANCE DATA shown in this document are subject to change without notice.

©Copyright, Bell Helicopter Textron, Inc., 2006

®™, Bell Helicopter, Bell Helicopter Textron Inc., Bell 206B3, 206L-4, 407, 427, 430, 412, 609, JetRanger and LongRanger are registered trademarks of Bell Helicopter Textron Inc.

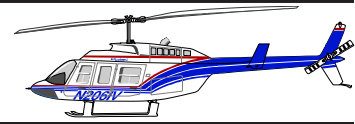

EXTERIOR DIMENSIONS STANDARD LOW SKID GEAR

206L4
STD GEAR

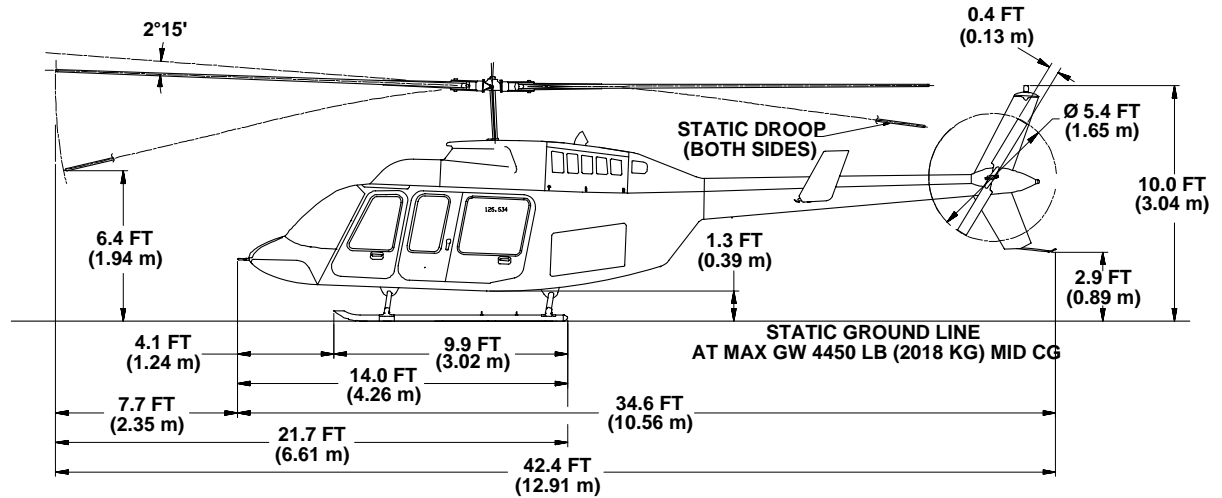
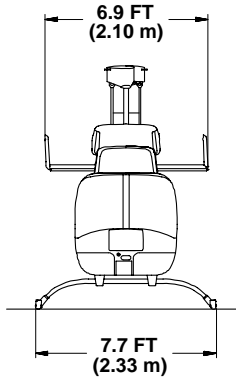
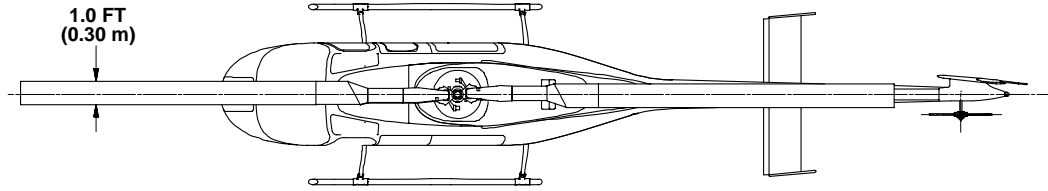

OPTIONAL HIGH SKID GEAR w/AAI FLIGHTSTEP®

206L4
HIGH SKID GEAR

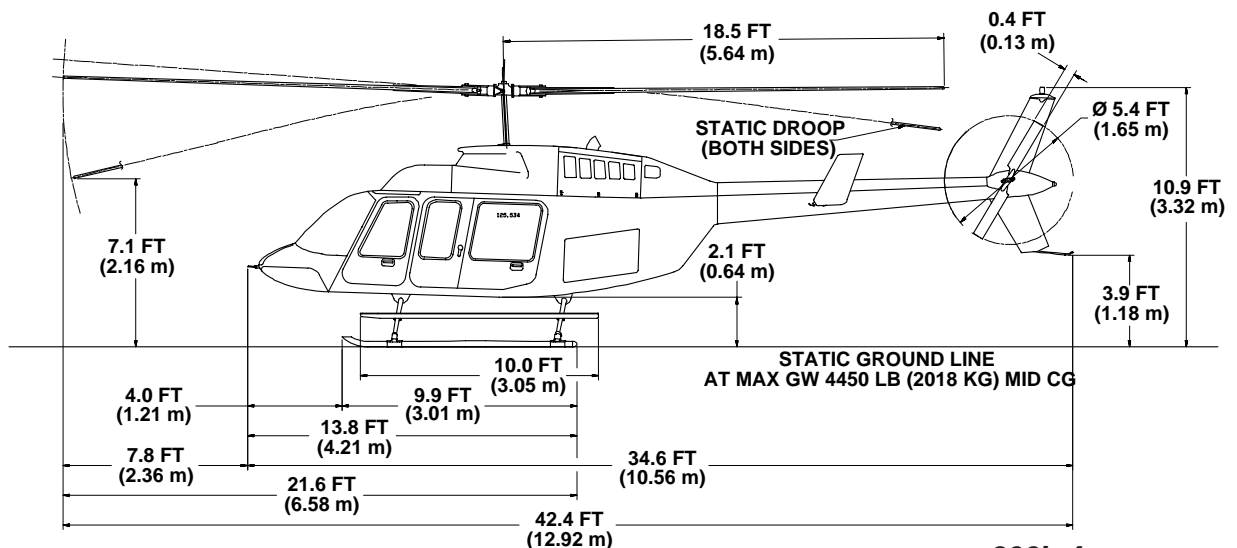
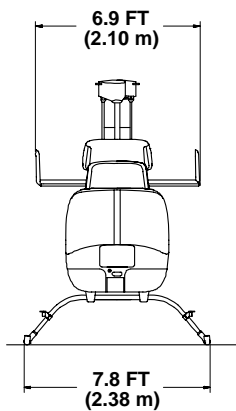
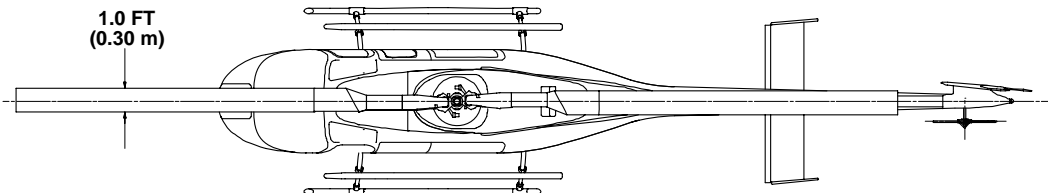

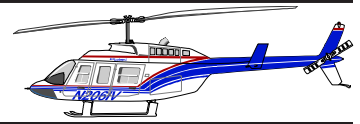

OPTIONAL EMERGENCY FLOAT GEAR w/ AAI FLOATSTEP®

206L4
FLOAT KIT

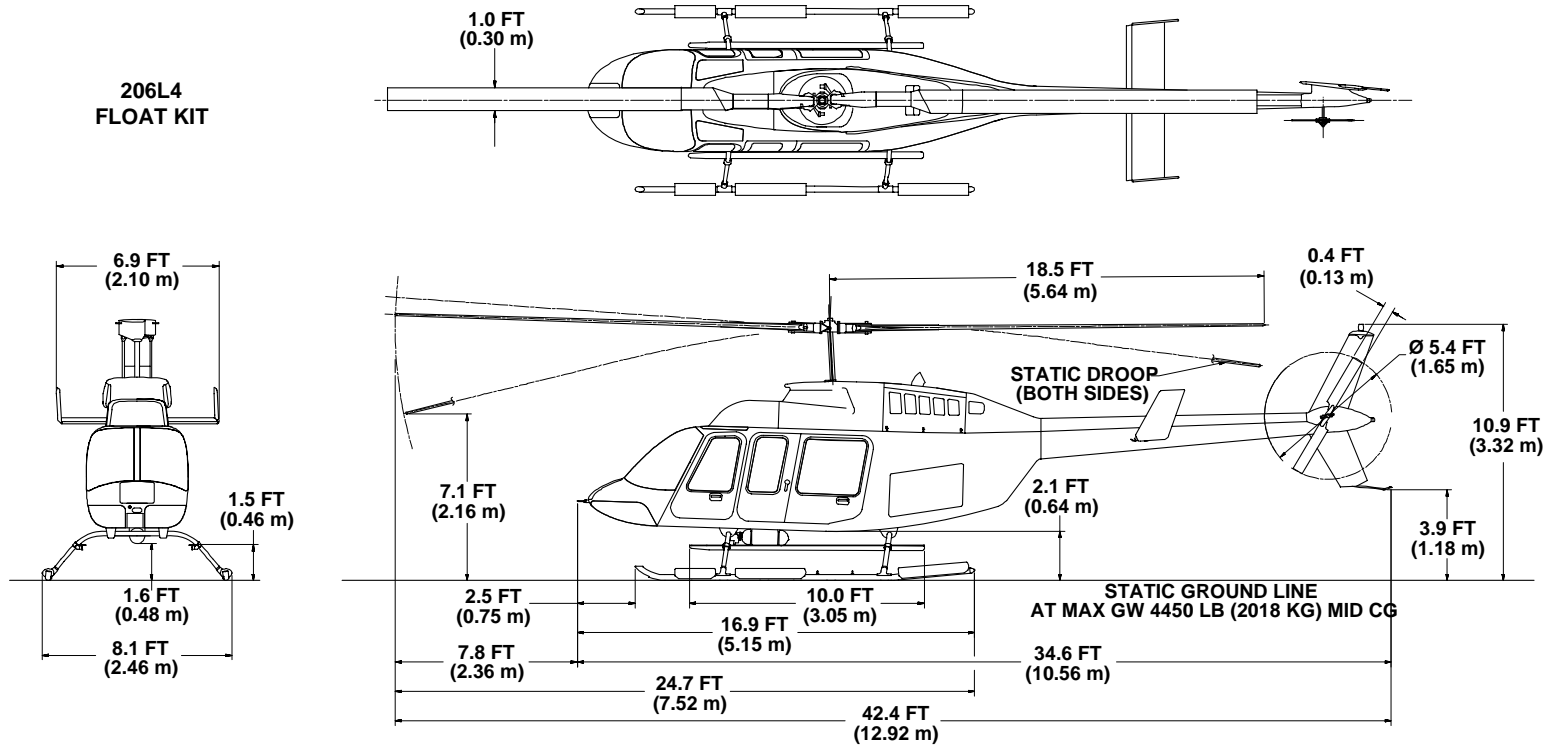

MINIMUM HANGAR SIZE*
8.1 FT X 42.5 FT
[2.5 M X 13.0 M]

*ALLOWANCE SHOULD BE MADE FOR HIGH SKID GEAR,
 GROUND WHEELS, EMPTY FUEL CONDITION, AND DOOR LIP
 WHEN CONSIDERING HANGAR DOOR WIDTH AND HEIGHT



CABIN DIMENSIONS

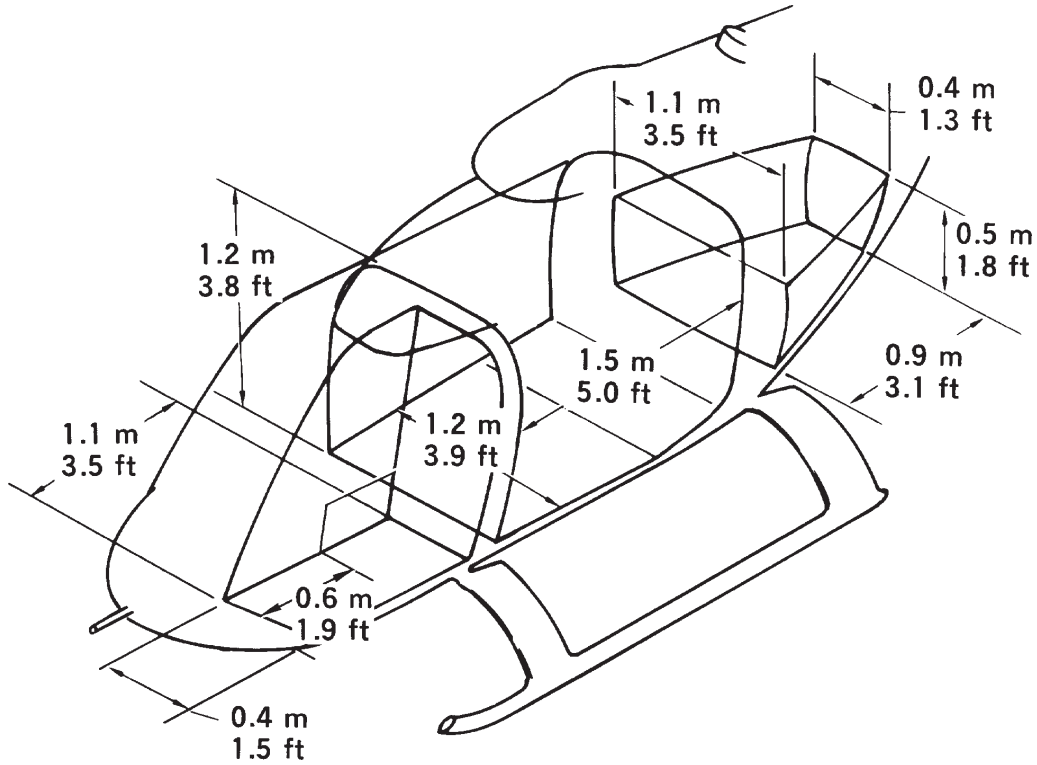

Approximate cargo space:

Aft Cabin-2.2 cubic meters (80 cubic feet)

Left front-0.6 cubic meters (20 cubic feet)

Baggage compartment-0.45 cubic meters
(16 cubic feet)

Floor loading:

Cabin-3.7 kg/sq. meter (75 lb/ sq. foot)

Baggage-4.2 kg/sq. meter (86 lb/sq. foot)

Max Baggage weight-113 kg (250 pounds)



DOOR DIMENSIONS

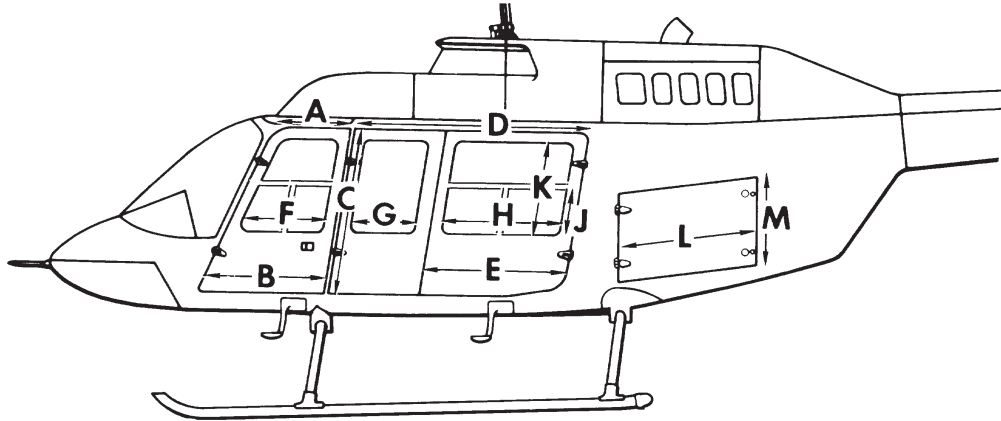

	cm	in		cm	in
A	49.5	19.5	G	36.8	14.5
B	78.7	31.0	H	76.2	30
C	104	41	J	27.9	11
D	152.4	60.0	K	70.0	24
E	91.4	36.0	L	94.0	37
F	43.2	17	M	58.4	23



SPECIFICATION SUMMARY [U. S. Units]

(Serial No. 52304 & Subsequent)

<u>WEIGHTS</u>	<u>LBS</u>
Standard Configuration Weight (Note 1)	2327
Normal Gross Weight	4450
External Load Gross Weight	4550
Standard Configuration Useful Load (Gross Weight-Standard Configuration)	2123
Maximum External Load (Cargo Hook Limit)	2000

Note 1: Includes thirteen (13.0) pounds of engine oil. **Ballast** is not included in standard configuration weight (ballast is a function of installed equipment).

PERFORMANCE SUMMARY: (International Standard Day Except as Noted)

• • • REFER TO DEMONSTRATED TAKEOFF & LANDING AND MAXIMUM OPERATING ALTITUDE NOTES ON THE PERFORMANCE CHARTS • • •

<u>TAKEOFF, GROSS WEIGHT</u>		<u>LBS</u>	<u>3600</u>	<u>4000</u>	<u>4450</u>
IGE Hovering Ceiling (2.5ft skid height)	ISA	ft	20,000+	17,600	10,000
	ISA+20 C	ft	18,300	15,100	7730
	ISA+30 C	ft	16,500	13,100	6660
OGE Hovering Ceiling	ISA	ft	16,600	13,600	6500
	ISA+20 C	ft	13,800	10,500	4200
	ISA+30 C	ft	11,500	7600	3100
Service Ceiling MCP, (100 ft/min)	ISA	ft	20,000+	20,000+	10,000
	ISA+20 C	ft	20,000+	19,300	7730
	ISA+30 C	ft	20,000+	17,300	6660
Range @ LRC Speed (Average Gross Weight, Full Fuel)	ISA,SL	nm	336	332	324
	ISA,SL	kn	116	114	112
	ISA,5000 ft	nm	382	372	357
	ISA,5000 ft	kn	118	117	114
	ISA,SL	kn	115	113	110
MCP Speed @ Takeoff Gross Weight	ISA+20 C,SL	kn	118	115	111
	ISA,5000 ft	kn	120	117	111
	ISA+20 C,5000 ft	kn	122	118	107
	ISA,SL	hr	3.9	3.8	3.7
Endurance @ Loiter 52 kn (No Reserve)	ISA,SL	hr	3.9	3.8	3.7
	ISA,5000 ft	hr	4.5	4.3	4.1

ENGINE POWER RATINGS:

(Rolls-Royce 250-C30P) Uninstalled Thermodynamic Rating

Takeoff , SHP	726
Maximum Continuous, SHP	630

TRANSMISSION RATING:

Takeoff , SHP	490
Maximum Continuous, SHP	370

FUEL:

Type	Aviation Turbine
Capacity (Usable)	110.7 Gallons

THE DATA SET FORTH ON THIS DOCUMENT ARE GENERAL IN NATURE AND MAY VARY WITH CONDITIONS. FOR PERFORMANCE DATA AND OPERATING LIMITATIONS FOR ANY SPECIFIC FLIGHT MISSION, REFERENCE MUST BE MADE TO THE APPROVED FLIGHT MANUAL.

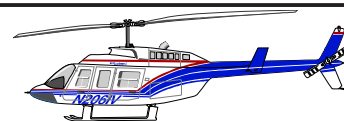

SPECIFICATION SUMMARY [Metric Units]

(Serial No. 52304 & Subsequent)

<u>WEIGHTS</u>	<u>KG</u>
Standard Configuration Weight (Note 1)	1056
Normal Gross Weight	2018
External Load Gross Weight	2064
Standard Configuration Useful Load (Gross Weight-Standard Configuration)	962
Maximum External Load (Cargo Hook Limit)	907

Note 1: Includes 5.9 kilograms of engine oil. **Ballast** is not included in standard configuration weight (ballast is a function of installed equipment).

PERFORMANCE SUMMARY: (International Standard Day Except as Noted)

• • • REFER TO DEMONSTRATED TAKEOFF & LANDING AND MAXIMUM OPERATING ALTITUDE NOTES ON THE PERFORMANCE CHARTS • • •

<u>TAKEOFF, GROSS WEIGHT</u>		<u>KG</u>	<u>1633</u>	<u>1814</u>	<u>2064</u>
IGE Hovering Ceiling (0.8M skid height)	ISA	M	6096+	5464	3048
	ISA+20 C	M	5578	4602	2356
	ISA+30 C	M	5029	3993	2030
OGE Hovering Ceiling	ISA	M	5060	4145	1981
	ISA+20 C	M	4026	3200	1280
	ISA+30 C	M	3505	2316	945
Service Ceiling MCP, (0.5 M/S)	ISA	M	6096+	6096+	3048
	ISA+20 C	M	6096+	5883	2356
	ISA+30 C	M	6096+	5273	2030
Range @ LRC Speed (Average Gross Weight, Full Fuel)	ISA,SL	km	623	615	600
	ISA,SL	km/h	215	211	207
	ISA,1524 M	km	708	689	662
	ISA,1524 M	km/h	219	217	211
MCP Speed @ Takeoff Gross Weight	ISA,SL	km	213	209	204
	ISA+20 C,SL	km	219	213	206
	ISA,1524 M	km/h	222	217	206
	ISA+20 C,1524M	km/h	226	219	198
Endurance @ Loiter 96 km/h (No Reserve)	ISA,SL	hr	3.9	3.8	3.7
	ISA,1524M	hr	4.5	4.3	4.1

ENGINE POWER RATINGS:

(Rolls-Royce 250-C30P)Uninstalled Thermodynamic Rating

Takeoff , kW	541
Maximum Continuous, kW	470

TRANSMISSION RATING:

Takeoff , kW	365
Maximum Continuous, kW	277

FUEL:

Type	Aviation Turbine
Capacity (Usable)	419.0 Liters

THE DATA SET FORTH ON THIS DOCUMENT ARE GENERAL IN NATURE AND MAY VARY WITH CONDITIONS. FOR PERFORMANCE DATA AND OPERATING LIMITATIONS FOR ANY SPECIFIC FLIGHT MISSION, REFERENCE MUST BE MADE TO THE APPROVED FLIGHT MANUAL.

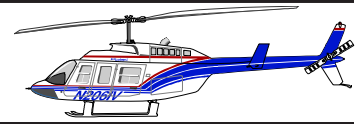

LONGRANGER IV SEATING

CREW SEATING - Two individual ergonomically designed seats with adjustable lumbar support, each equipped with seat belt, double strap shoulder harness and inertia reel, are located in the cockpit. The color and upholstery material for the seats, and interior trim of the cockpit match that which is selected for the cabin. The seat belts are black.

STANDARD INTERIOR

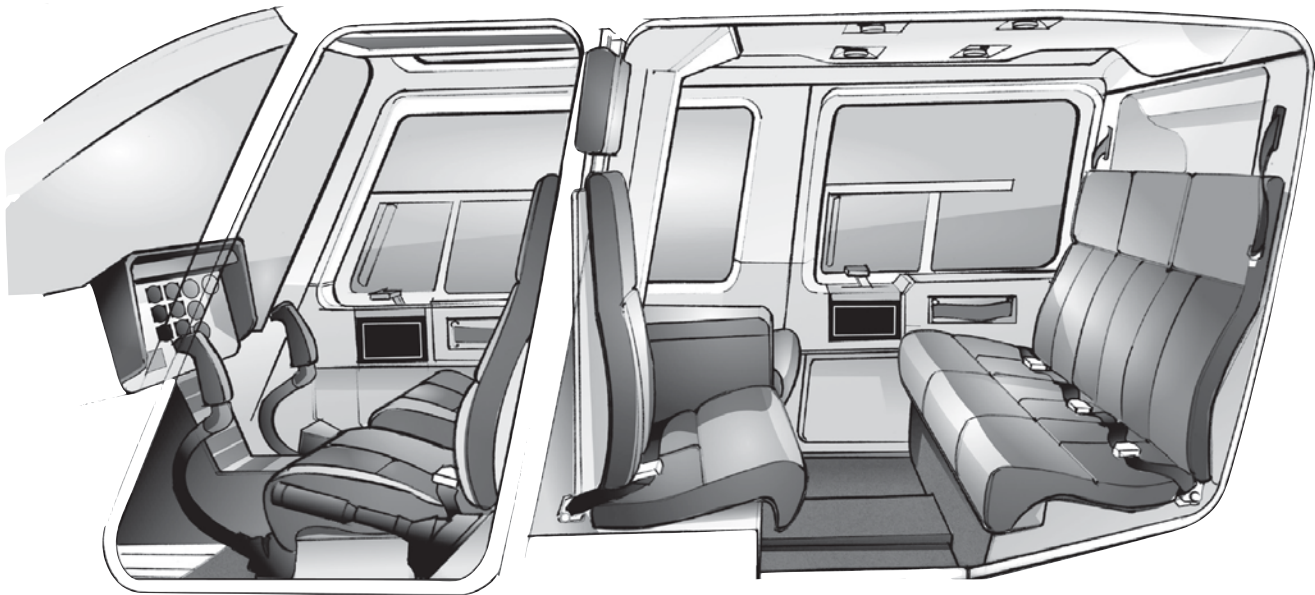

STANDARD SEATING & INTERIOR TRIM - The standard cabin seating consists of **five** ergonomically designed seats with individual seat belts and single strap shoulder harness, arranged with three equal width forward facing seats across the rear of the cabin and two individual rearward facing seats aft of the cockpit. Available with Grey, Blue, Red, or Tan upholstery with Black seat belts. The Standard Seats are upholstered in fabric. All vinyl, or fabric/vinyl is available as an **extra cost** option. **The standard interior trim** consists of full plastic closeouts on all airframe areas, vinyl covered arm rests, and molded plastic outboard headliners. The floor is covered in low loop blend carpet. The standard seating and interior trim are included in the basic aircraft weight.

Specifications subject to change without notice.

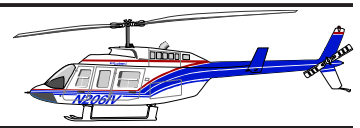

CORPORATE INTERIOR

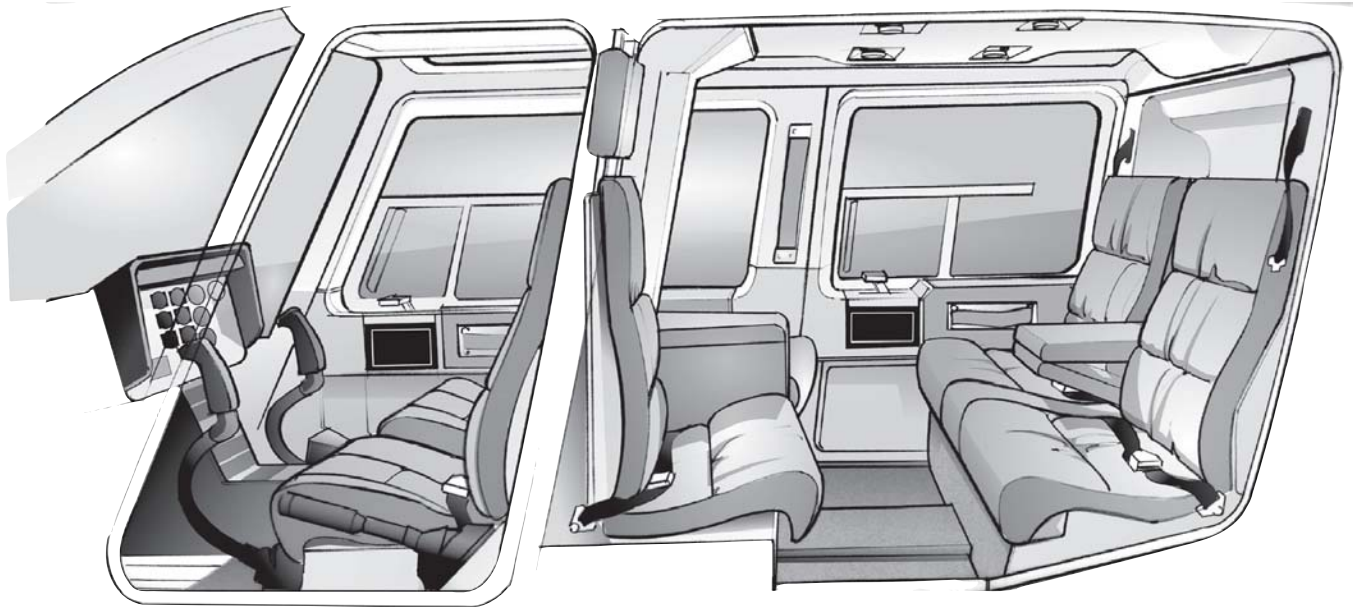

CORPORATE SEATING & INTERIOR TRIM - The corporate cabin seating consists of **five** 'Overstuffed Style' seats with individual seat belts and single strap shoulder harness, arranged with two extra wide forward facing **outboard** seats and a **middle** seat for occasional use across the rear of the cabin (with a fold down arm rest between the outboard seats) and two individual rearward facing seats aft of the cockpit. Available with Pewter, Mushroom, Dark Blue, Saddle, Burgundy, Smoke Grey, and Forest Green upholstery with color coordinated seat belts (Crew seat belts are black). Seats can be all fabric (basic ship), optional leather with fabric inserts or all leather with perforated leather inserts. **The corporate interior trim** consists of full plastic closeouts on all airframe areas, fabric covered outboard headliner blankets, and armrests covered with color coordinated leather. Carpet is 100% wool cut pile. The corporate seating and interior trim (and corporate soundproofing) **increase** the basic aircraft empty weight **9 lbs. (4.1 kg.)**.

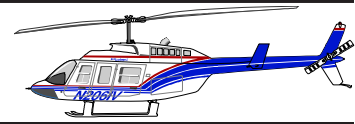

STANDARD CONFIGURATION ***(Items Included In List Price)***

AIRFRAME

Cabin; bonded aluminum honeycomb, and semi-monocoque structure
Doors (five), one hinged double door & copilot door on left side, pilot door & passengers door on right side
Landing gear, tubular skid type with replaceable skid shoes
Locks for cabin doors and luggage compartment
Luggage compartment (16 ft³ [.45 M³], 250 lbs [113 Kg]cap), with Composite Door
Provisions for mooring, jacking and single point lifting
Tailboom, monocoque structure with vertical fin and fixed stabilizer with synchronized elevator
Tail skid (tail rotor guard)
Windshield (and Chin Windows), clear plexiglass
Windows, blue tinted plexiglass with sliding panels in doors, Crew "Wedge" Windows, Bulged Panel Windows, Passenger Cabin "Wedge" Windows
Three color exterior paint schemes
Rain gutters

INTERIOR

Standard 7-place interior with soundproofing, carpeting, ash trays & data case. Color options available for upholstery & carpet
7-place shoulder harnesses, dual straps in cockpit, single strap in cabin
Fire extinguisher, cabin
First aid kit
Parcel shelf (behind aft seat)
Ram air ventilation system

POWERPLANT

Rolls-Royce Model 250-C30P gas turboshaft engine
Fuel control, Bendix
Fuel filter (eliminates anti-ice additive requirement)
Fuel pump, engine mounted
Fuel boost pumps (2 canister type) submerged in main fuel tank
Fuel system, 110.7 gal [419 liter] capacity
Oil system, 1.5 gal [5.7 liter] capacity
Compressor wash provisions

ROTORS AND CONTROLS

Main rotor, semi-rigid, two-bladed, see-saw type with precone and underslung feathering axis. All metal blades that are moisture proofed and epoxy encapsulated. Flap restraints. **CHOICE** of **STANDARD** [black top-white bottom] or **HIGH VISIBILITY** [orange/white top-white bottom] painted rotor blades
Tail rotor; semi-rigid, two-bladed, see-saw type
Hydraulic boost system (pump and reservoir module)
Mechanical flight control linkages throughout
Pilots Cyclic Grip has provisions for Optional Equipment Control

TRANSMISSION DRIVE SYSTEM

Focused pylon mounted with nodal beam
Freewheeling unit (between engine and main transmission)
Kaflex (non-lubricated) input drive shaft
Gearbox, tail rotor with 2.3:1 spiral bevel gear reduction
Hydraulic pump (for cyclic and collective boost controls)
Main transmission 2 stage 15.22:1 planetary reduction
Oil cooler
Oil filter with replaceable type cartridge
Oil pump, constant pressure

Specifications subject to change without notice.



STANDARD CONFIGURATION (continued) ***(Items Included In List Price)***

FLIGHT AND ENGINE INSTRUMENTS

Clock, Digital Quartz Crystal Chronometer
Compass, magnetic
Dual tachometer (rotor and engine)
Inclinometer
Indicator, airspeed
Indicator, altimeter
Indicator, engine oil pressure/temperature
Indicator, free air temperature
Indicator, fuel quantity with forward cell quantity switch
Indicator, fuel pressure/generator load meter
Indicator, torque meter pressure
Indicator, transmission oil pressure/temperature
Indicator, turbine outlet temperature with over temp light
Hour meter

MONITORING SYSTEM

Caution indication lights:
Baggage Door Open
Fuel boost pump inoperative, left & right
Engine failure warning
Fuel filter by-pass indicator
Transmission oil pressure
Transmission oil temperature
Tail rotor gearbox chip detector
Engine chip detectors
Transmission chip detector
Freewheeling unit
Battery temperature sensor
Battery hot
Engine out and low rotor RPM warning lights and horn with mute switch (Low RPM or engine out)
Fuel Low Warning
Generator failure

ELECTRICAL

28 volt DC system
Battery, 17 amp-hr nickel-cadmium
External power and grounding receptacle
Lights:
Anti-collision strobe
Cockpit/map
Instrument
Aft cabin
Landing (two 250 watt)
Position
Starter-generator (180 ampere)
Voltage regulator
28 volt outlet in cabin
Heated pitot tube

MISCELLANEOUS

Covers, turbine inlet and exhaust stack
Cover pitot tube
Flight bag
Ground handling wheels w/lift tube
Operating manuals:
Aircraft log book
Engine log book
Engine operating manual
Engine parts manual
Flight manual
Illustrated parts catalog
Maintenance & overhaul manual
Tie-down assemblies, main rotor and tail rotor



OPTIONAL ACCESSORIES

***** REFER TO NOTES FOR KIT COMPATIBILITY *****

ADDITIONAL KITS & STC ITEMS MAY BE AVAILABLE FOR FACTORY INSTALLATION. PLEASE CONSULT SALES OR CONTRACT PERSONNEL REGARDING SPECIAL NEEDS PRIOR TO SELECTION OF FINAL CONFIGURATION.

Kit Description	Wt (lbs)	Wt (Kg)	Notes
AIRFRAME			
HIGH SKID GEAR (INCL AAI FLIGHT STEPS)	54.8	24.9	(1, 11)
DUAL CONTROLS	8.7	3.9	
LIGHT WEIGHT POP-OUT FLOATS	159.0	72.1	(1)
SKID GEAR FAIRINGS	10.3	4.7	(2)
AUDIO			
AFT AUDIO ICS - ONE STATION (TELEPHONE TYPE HANDSET)	3.0	1.4	
AVIONICS			
VHF EQUIPMENT (KX-155)	7.7	3.5	
TRANSPONDER PROVISIONS (KT-76A)	1.0	0.5	(3)
TRANSPONDER EQUIPMENT (KT-76A)	2.5	1.1	(3)
ADF EQUIPMENT (KR-87)	7.1	3.2	
OMNI W/ PROVISIONS (KI208)	3.0	1.4	
TRANSPONDER PROVISIONS (DIGITAL) (KT-70)	1.0	0.5	(3)
TRANSPONDER EQUIPMENT (DIGITAL) (KT-70)	3.9	1.8	(3)
VHF/ADF PROVISIONS W/ AUDIO PANEL (KMA24H-71)	10.3	4.7	
ENCODING ALTIMETER	0.9	0.4	(1, 3)
BLIND ENCODING ALTIMETER	1.9	0.9	(3)
AVIONICS			
PARTICLE SEPARATOR	12.5	5.7	(1)
ENVIRONMENT			
STANDARD HEADLINER w/ A/C DUCTS [for STC A/C]	6.2	2.8	(4)
EQUIPMENT			
HIGH ALTITUDE TAIL ROTOR	13.0	5.9	(1, 5)
REVERSE FLOW SNOW BAFFLE	4.9	2.2	
CARGO HOOK EQUIPMENT	16.7	7.6	
CARGO HOOK PROVISIONS	3.6	1.6	
LITTER PROVISIONS & EQUIPMENT [Basic Dual Litter System]	49.5	22.5	
LITTER PROVISIONS & EQUIPMENT W/ AIR SPLINT MOD.	51.9	23.5	(6)
ROTOR BRAKE	13.3	6.0	
INSTRUMENT			
FLIGHT INSTRUMENTS [for less Dir. Gyro. See Note/Credits]	10.3	4.7	(7)
INTERIOR			
CORPORATE SEATS	8.4	3.8	(1, 10)
SOUND-PROOFING	13.0	5.9	

Specifications subject to change without notice.

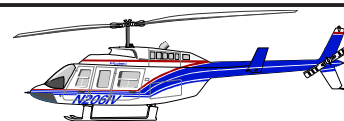

OPTIONAL ACCESSORIES (continued)

..... REFER TO NOTES FOR KIT COMPATIBILITY

Kit Description	Wt (lbs)	Wt (Kg)	Notes
PAINT			
MARKINGS FOR HIGH VIS. M/R BLADES (WHITE & ORANGE)	0.0	0.0	(8)
STC's			
ENVIRONMENT			
AIR CONDITIONER EQUIPMENT [Air Com]	113.6	51.6	(4)
EQUIPMENT			
WIRE STRIKE - RECOMMENDED KIT - SEE NOTE			(9)
LOW SKIDS	16.4	7.4	
HIGH SKIDS	17.4	7.9	
Credits			
EQUIPMENT			
GROUND HANDLING WHEELS	95.0	43.1	
INSTRUMENT			
DIRECTIONAL GYRO	-3.6	-1.6	
PAINT			
NO EXTERIOR PAINT	-16.7	-7.6	
WHITE PAINT ONLY	0.0	0.0	

All equipment kits require Provision Kits prior to installation

List.

- 1) Price and/or weight includes credit for basic ship hardware.
- 2) Only compatible with low skid gear.
- 3) Encoding Altimeter or Blind Encoder required to enable Mode C or Mode S Altitude reporting. Customer is responsible for obtaining Aircraft ID code for Mode S.
- 4) The Standard Headliner with A/C Ducts is required for installation of the STC Air Com airconditione
- 5) Requires installation of Encoding Altimeter or Blind Encoder.
- 6) When the Air Splint Mod is installed in the elevated position, the **upper litter** may NOT be used. If the Air Splint Mod is in the normal position, both upper and lower litters may be used.
- 7) Flight Instruments Less D. G. requires a Sales Order Amendment (Kit number is the SAME).
- 8) Standard or High Visibility Main Rotor Blade Paint to be specified by Sales Order.
- 9)The Wire Strike Kit is a RECOMMENDED extra cost option. The customer must specify on the Purchase Agreement for the WSPS Kit NOT to be installed.
- 10) Material to be called out on Sales Order. Can be Leather, Fabric/Leather, or Fabric.
- 11) "J Steps" (4 each) may be substituted for the AAI FlightSteps by Sales Order. Substitution of "J Steps" reduce High Skid Kit installed weight by 20.0 lbs (9.1 kg.).

STC Kits - Select Supplemental Type Certificated Optional Equipment Kits are available for installation at the Bell Helicopter Textron factory. Please contact your Bell Sales Representative for availability and pricing information.

P.O.R. - Priced On Request.

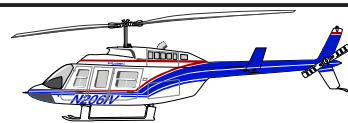

INTENTIONALLY LEFT BLANK



HELICOPTER PERFORMANCE
IGE & OGE HOVER, SERVICE CEILING
ROLLS-ROYCE 250-C30P ENGINE
FOR
STANDARD & HIGH ALTITUDE TAIL ROTOR
BASIC INLET INSTALLED
MINIMUM SPEC. ENGINE

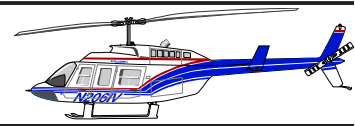

**HOVERING CEILING IGE 2.5 FT
ROLLS-ROYCE 250-C30P ENGINE AT TOP
STANDARD TAIL ROTOR**

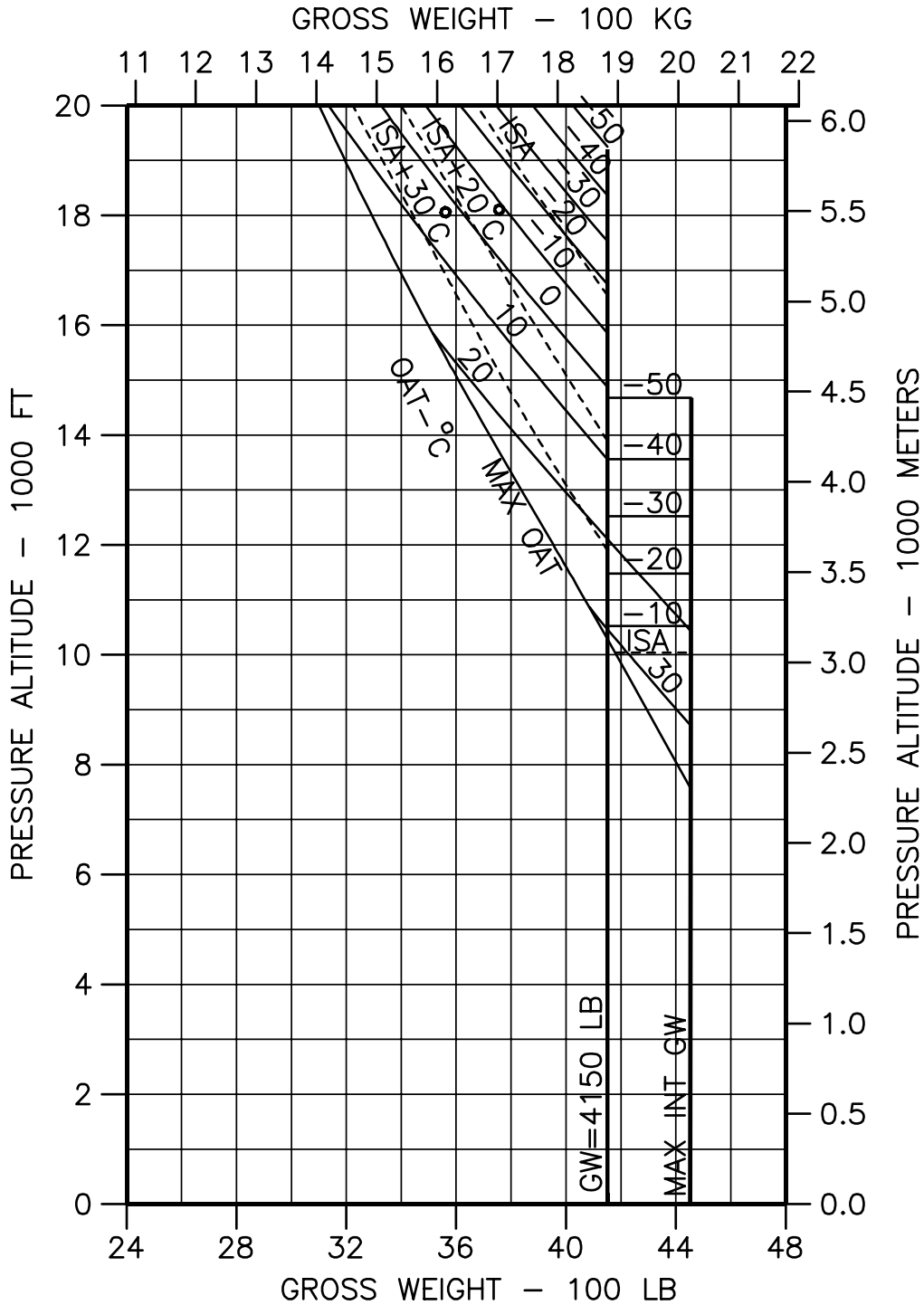

NOTE: TAKEOFF AND LANDING HAS NOT BEEN DEMONSTRATED AND IS NOT APPROVED ABOVE 15,000 FEET / 4572 METERS DENSITY ALTITUDE.

THE DATA SET FORTH ON THIS DOCUMENT ARE GENERAL IN NATURE AND MAY VARY WITH CONDITIONS. FOR PERFORMANCE DATA AND OPERATING LIMITATIONS FOR ANY SPECIFIC FLIGHT MISSION, REFERENCE MUST BE MADE TO THE APPROVED FLIGHT MANUAL.



HOVERING CEILING OGE ROLLS-ROYCE 250-C30P ENGINE AT TOP STANDARD TAIL ROTOR

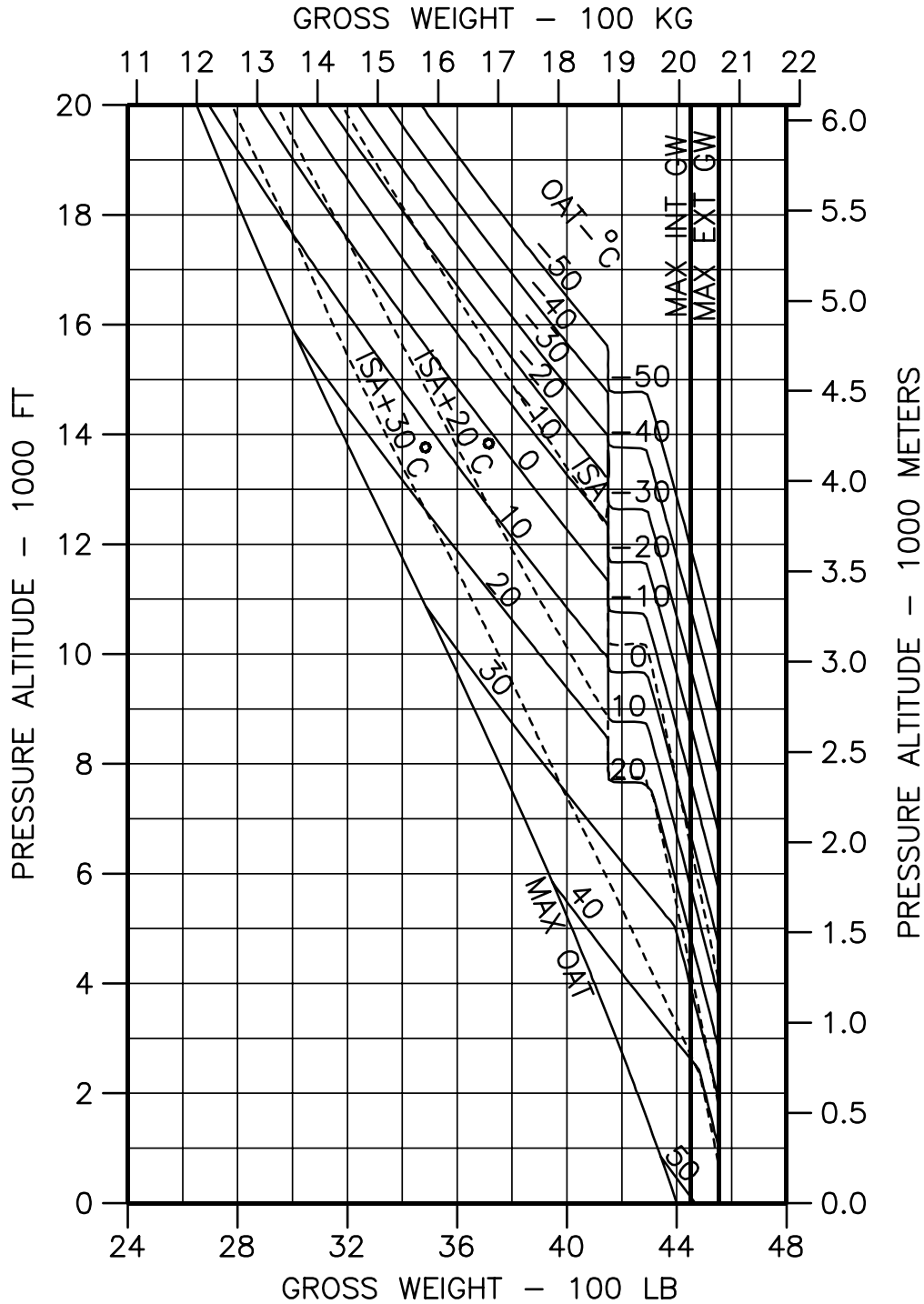

NOTE: TAKEOFF AND LANDING HAS NOT BEEN DEMONSTRATED AND IS NOT APPROVED ABOVE 15,000 FEET / 4572 METERS **DENSITY ALTITUDE**.

THE DATA SET FORTH ON THIS DOCUMENT ARE GENERAL IN NATURE AND MAY VARY WITH CONDITIONS. FOR PERFORMANCE DATA AND OPERATING LIMITATIONS FOR ANY SPECIFIC FLIGHT MISSION, REFERENCE MUST BE MADE TO THE APPROVED FLIGHT MANUAL.

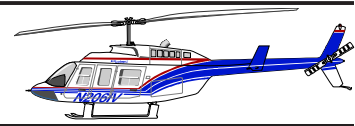

**HOVERING CEILING IGE 2.5 FT
ROLLS-ROYCE 250-C30P ENGINE AT TOP
HIGH ALTITUDE TAIL ROTOR**

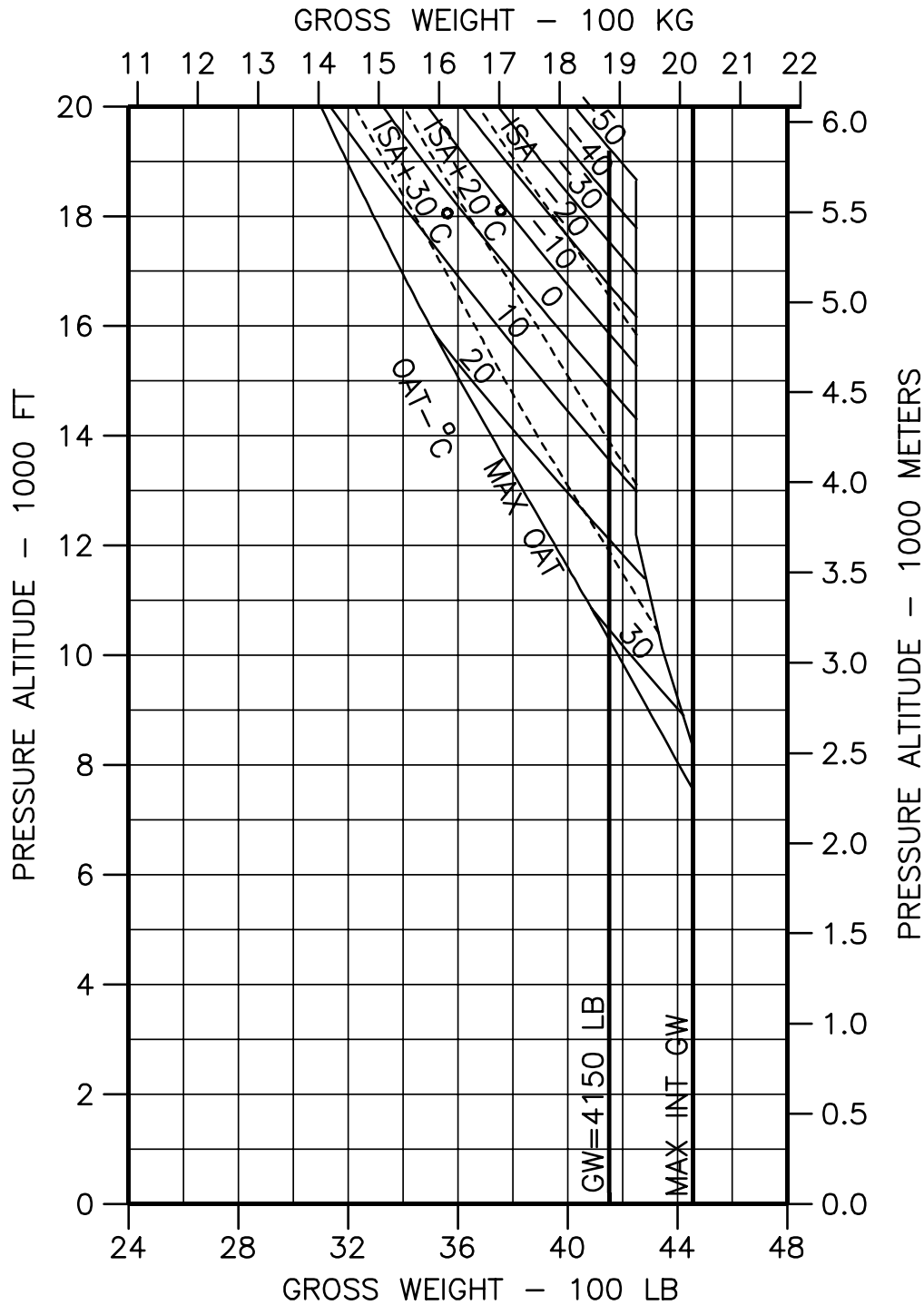

NOTE: TAKE OFF AND LANDING AT GROSS WEIGHTS ABOVE 4150 POUNDS/1882 KILOGRAMS IS SUBJECT TO **DENSITY ALTITUDE LIMITATION**, SEE THE FAA APPROVED ROTORCRAFT FLIGHT MANUAL SUPPLEMENT BHT-206L4-FMS-19.

THE DATA SET FORTH ON THIS DOCUMENT ARE GENERAL IN NATURE AND MAY VARY WITH CONDITIONS. FOR PERFORMANCE DATA AND OPERATING LIMITATIONS FOR ANY SPECIFIC FLIGHT MISSION, REFERENCE MUST BE MADE TO THE APPROVED FLIGHT MANUAL.



HOVERING CEILING OGE ROLLS-ROYCE 250-C30P ENGINE AT TOP HIGH ALTITUDE TAILROTOR

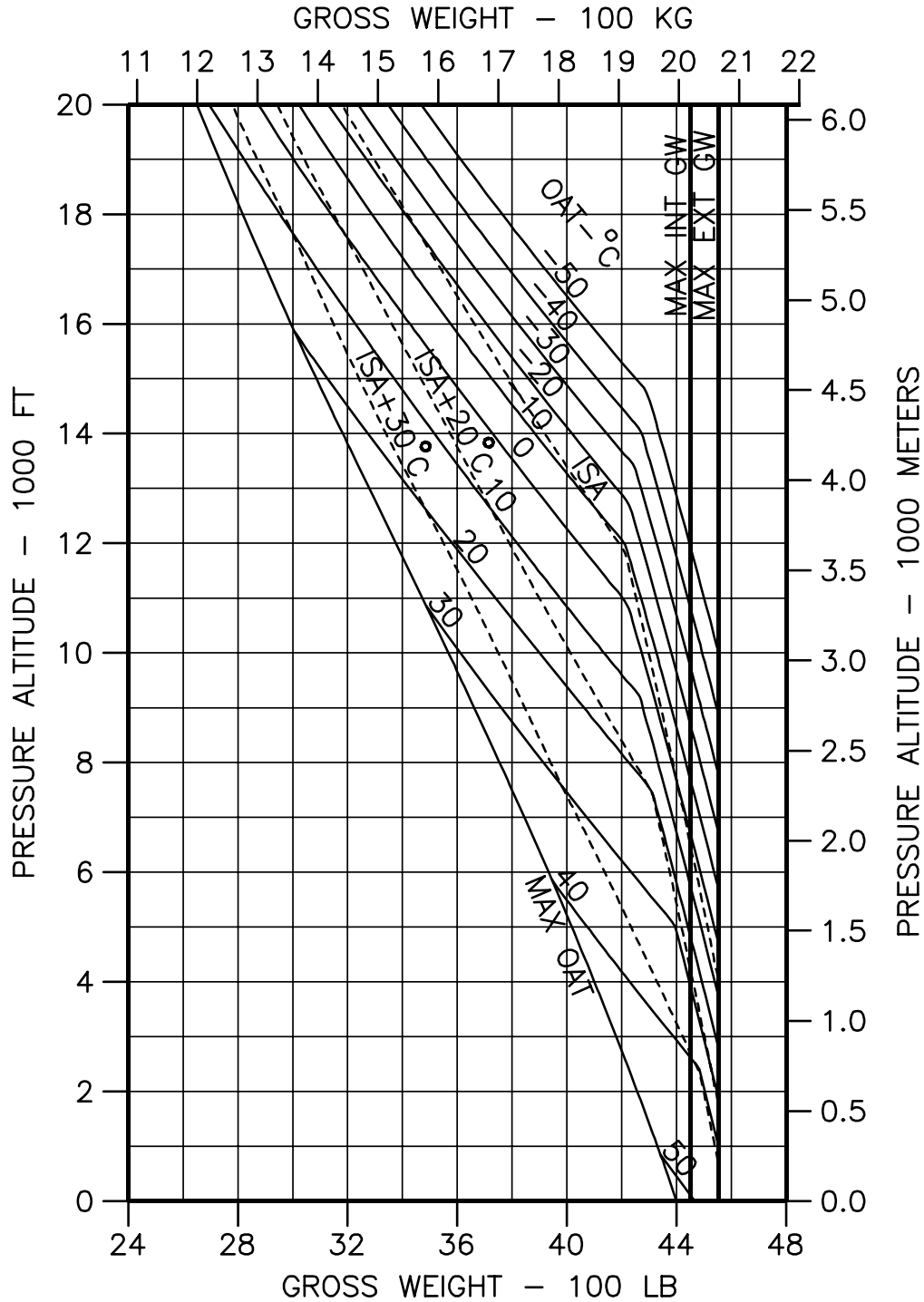

NOTE: TAKE OFF AND LANDING AT GROSS WEIGHTS ABOVE 4150 POUNDS/1882 KILOGRAMS IS SUBJECT TO **DENSITY ALTITUDE LIMITATION**, SEE THE FAA APPROVED ROTORCRAFT FLIGHT MANUAL SUPPLEMENT BHT-206L4-FMS-19.

THE DATA SET FORTH ON THIS DOCUMENT ARE GENERAL IN NATURE AND MAY VARY WITH CONDITIONS. FOR PERFORMANCE DATA AND OPERATING LIMITATIONS FOR ANY SPECIFIC FLIGHT MISSION, REFERENCE MUST BE MADE TO THE APPROVED FLIGHT MANUAL.

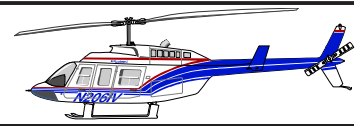

**SERVICE CEILING, STANDARD TAIL ROTOR
ROLLS-ROYCE 250-C30P ENGINE AT MCP
100 FPM (0.5 M/S) RATE OF CLIMB**

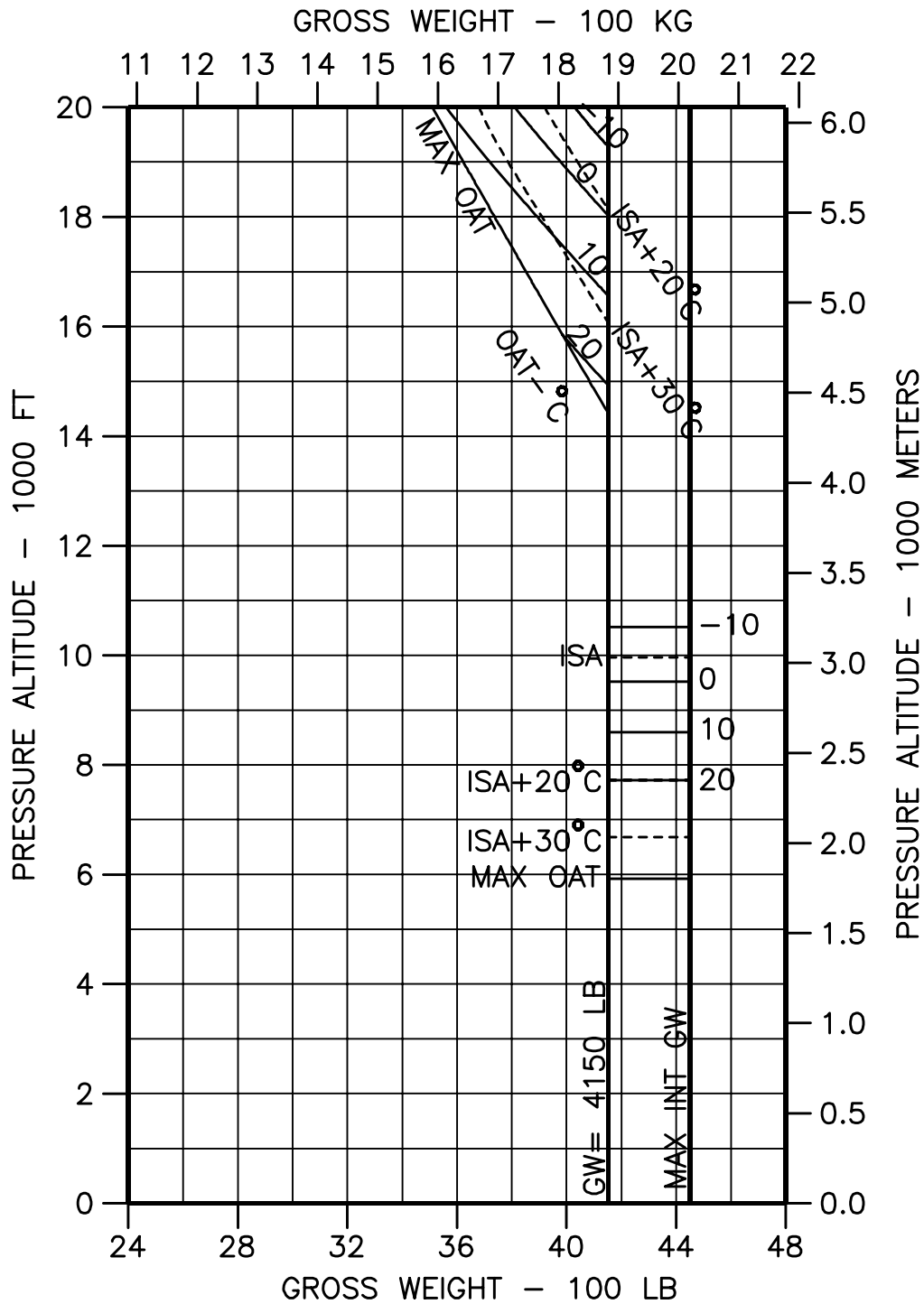

NOTE: MAXIMUM OPERATING ALTITUDE WITH STANDARD TAIL ROTOR FOR GROSS WEIGHTS ABOVE 4150 POUNDS/1882 KILOGRAMS IS 10,000 FEET / 3050 METERS DENSITY ALTITUDE.

THE DATA SET FORTH ON THIS DOCUMENT ARE GENERAL IN NATURE AND MAY VARY WITH CONDITIONS. FOR PERFORMANCE DATA AND OPERATING LIMITATIONS FOR ANY SPECIFIC FLIGHT MISSION, REFERENCE MUST BE MADE TO THE APPROVED FLIGHT MANUAL.



**SERVICE CEILING, HIGH ALTITUDE TAIL ROTOR
ROLLS-ROYCE 250-C30P ENGINE AT MCP
100 FPM (0.5 M/S) RATE OF CLIMB**

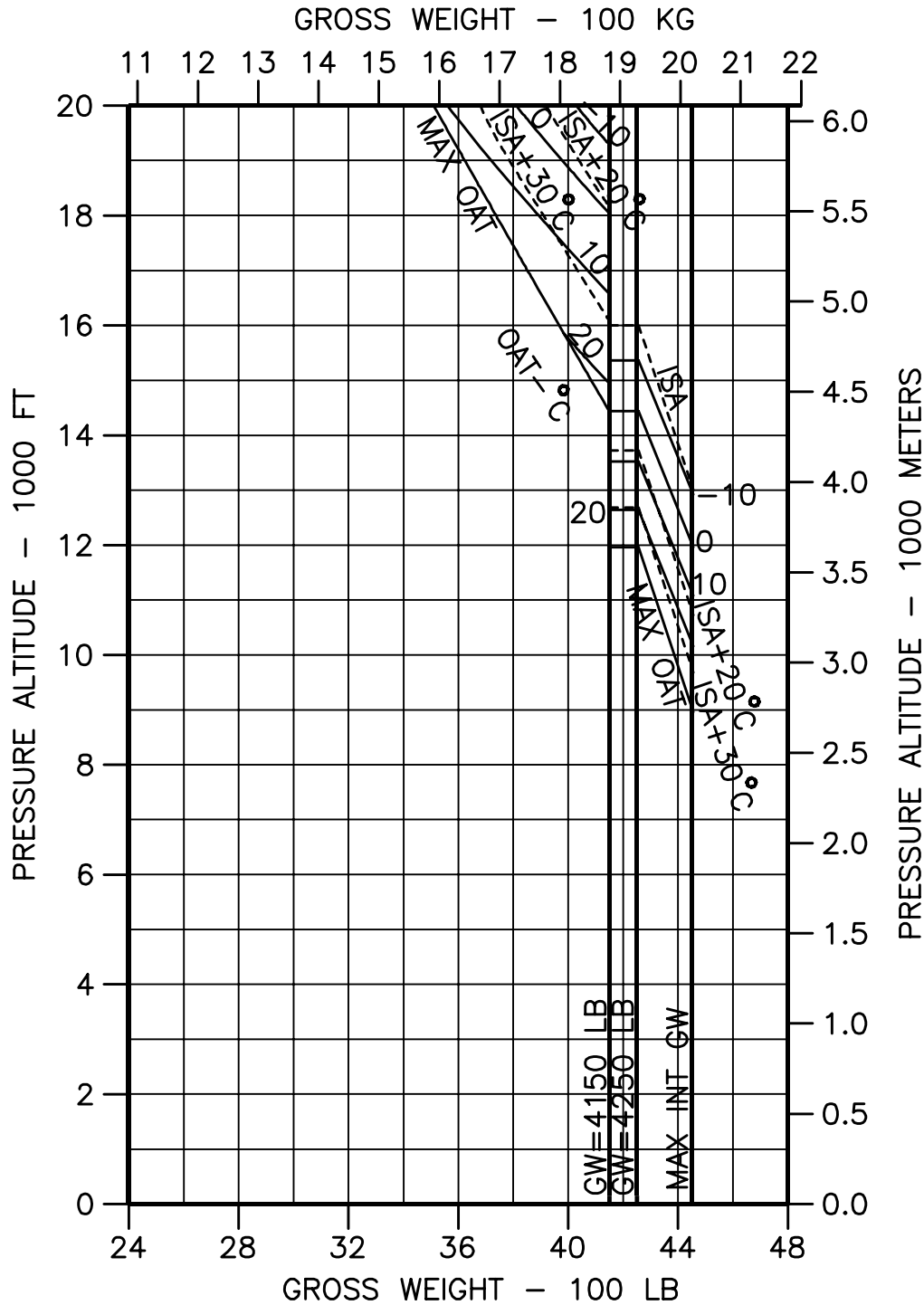

NOTE: MAXIMUM OPERATING ALTITUDE FOR GROSS WEIGHTS ABOVE 4150 POUNDS/1882 KILOGRAMS IS SUBJECT TO **DENSITY ALTITUDE LIMITATION**, SEE THE FAA APPROVED ROTORCRAFT FLIGHT MANUAL SUPPLEMENT BHT-206L4-FMS-19.

THE DATA SET FORTH ON THIS DOCUMENT ARE GENERAL IN NATURE AND MAY VARY WITH CONDITIONS. FOR PERFORMANCE DATA AND OPERATING LIMITATIONS FOR ANY SPECIFIC FLIGHT MISSION, REFERENCE MUST BE MADE TO THE APPROVED FLIGHT MANUAL.

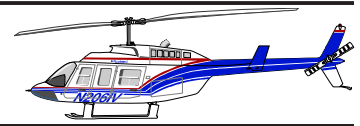

INTENTIONALLY LEFT BLANK

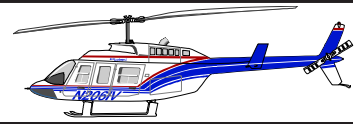

FUEL FLOW vs AIRSPEED
ISA & ISA+20° C
ROLLS-ROYCE 250-C30P ENGINE
BASIC INLET INSTALLED
LOW SKID GEAR WITHOUT FAIRINGS

**FOR PARTICLE SEPARATOR INSTALLED;
INCREASE FUEL FLOW TWO(2)LB/HR[ONE(1)KG/HR]
FOR CROSS TUBE FAIRINGS;
INCREASE AIRSPEED TWO(2)KNOTS[FOUR(4)KM/HR]**

NOTE: THE BEST ALLOWABLE CRUISE SPEED IS EITHER LONG RANGE CRUISE SPEED [LRC], OR WHEN SPEED IS LIMITED BY MAXIMUM CONTINUOUS CRUISE POWER [MCP] OR V_{NE} , THE MAXIMUM SPEED PERMITTED .

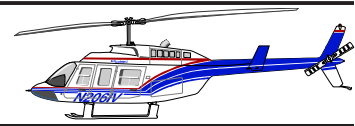

**FUEL FLOW VERSUS AIRSPEED
PRESSURE ALTITUDE = SEA LEVEL
OAT = +15 DEG C**

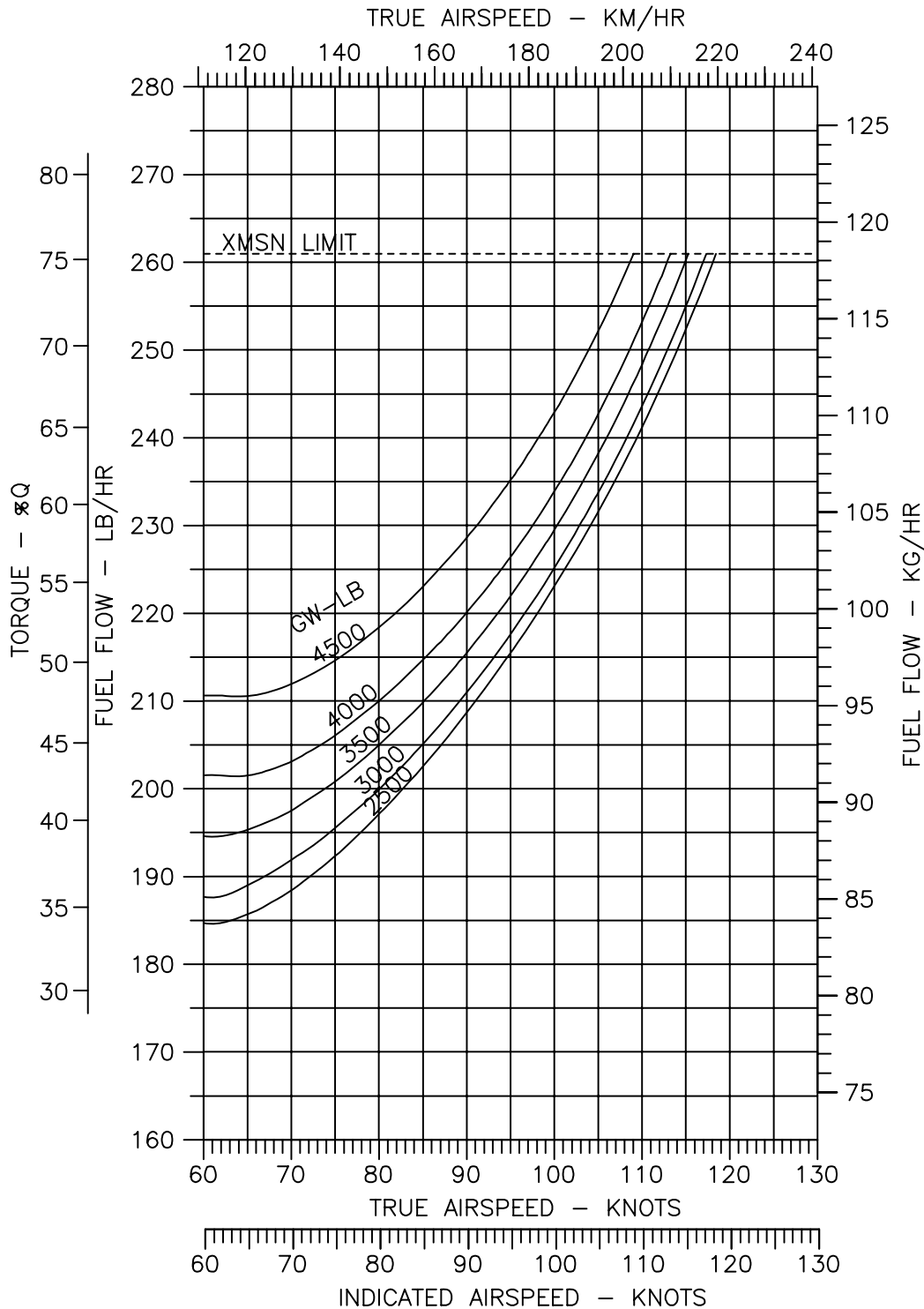

THE DATA SET FORTH ON THIS DOCUMENT ARE GENERAL IN NATURE AND MAY VARY WITH CONDITIONS. FOR PERFORMANCE DATA AND OPERATING LIMITATIONS FOR ANY SPECIFIC FLIGHT MISSION, REFERENCE MUST BE MADE TO THE APPROVED FLIGHT MANUAL.



**FUEL FLOW VERSUS AIRSPEED
PRESSURE ALTITUDE = 2000 FEET
OAT = +11 DEG C**

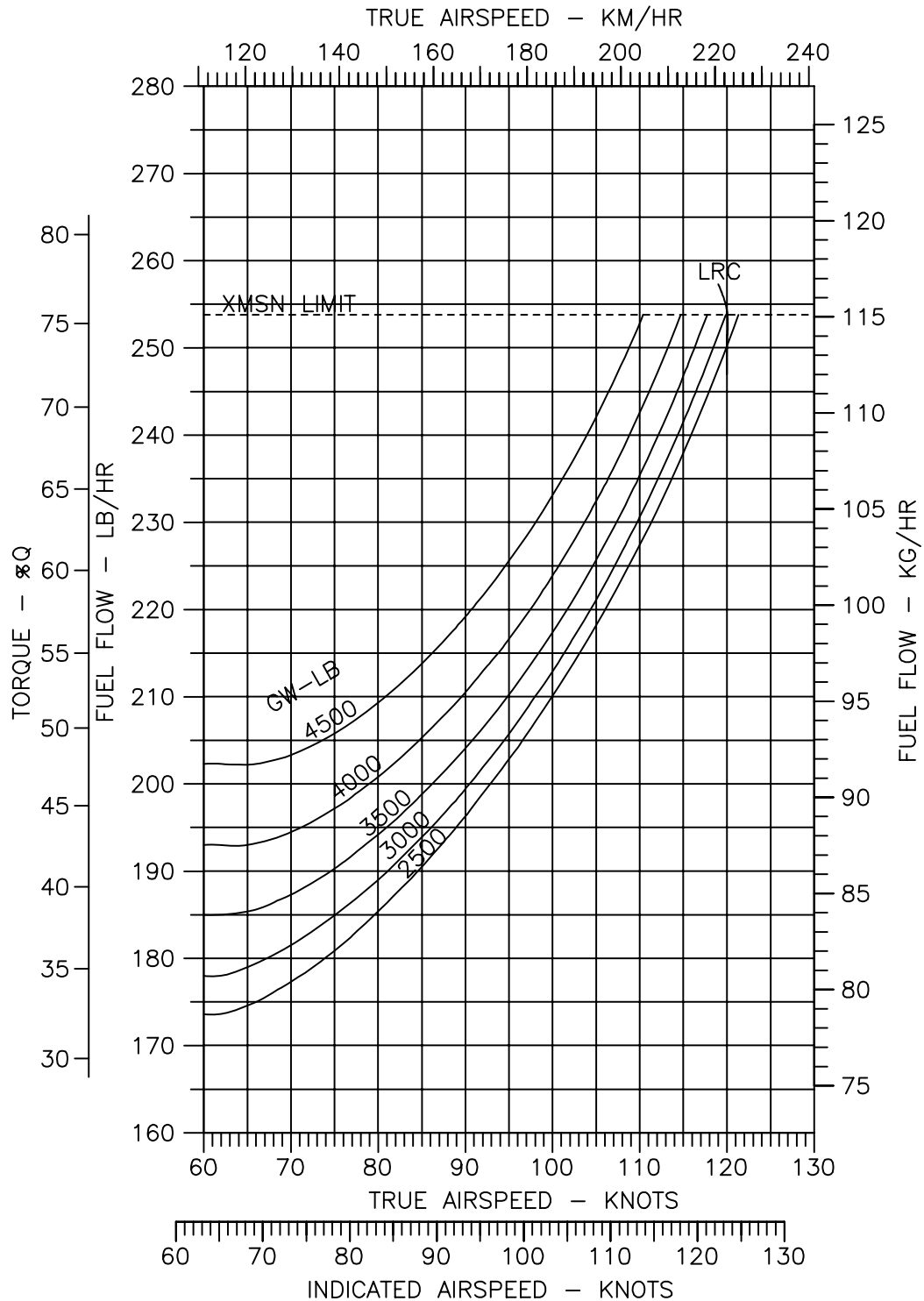

THE DATA SET FORTH ON THIS DOCUMENT ARE GENERAL IN NATURE AND MAY VARY WITH CONDITIONS. FOR PERFORMANCE DATA AND OPERATING LIMITATIONS FOR ANY SPECIFIC FLIGHT MISSION, REFERENCE MUST BE MADE TO THE APPROVED FLIGHT MANUAL.

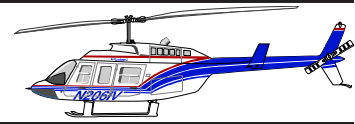

FUEL FLOW VERSUS AIRSPEED PRESSURE ALTITUDE = 4000 FEET OAT = + 7 DEG C

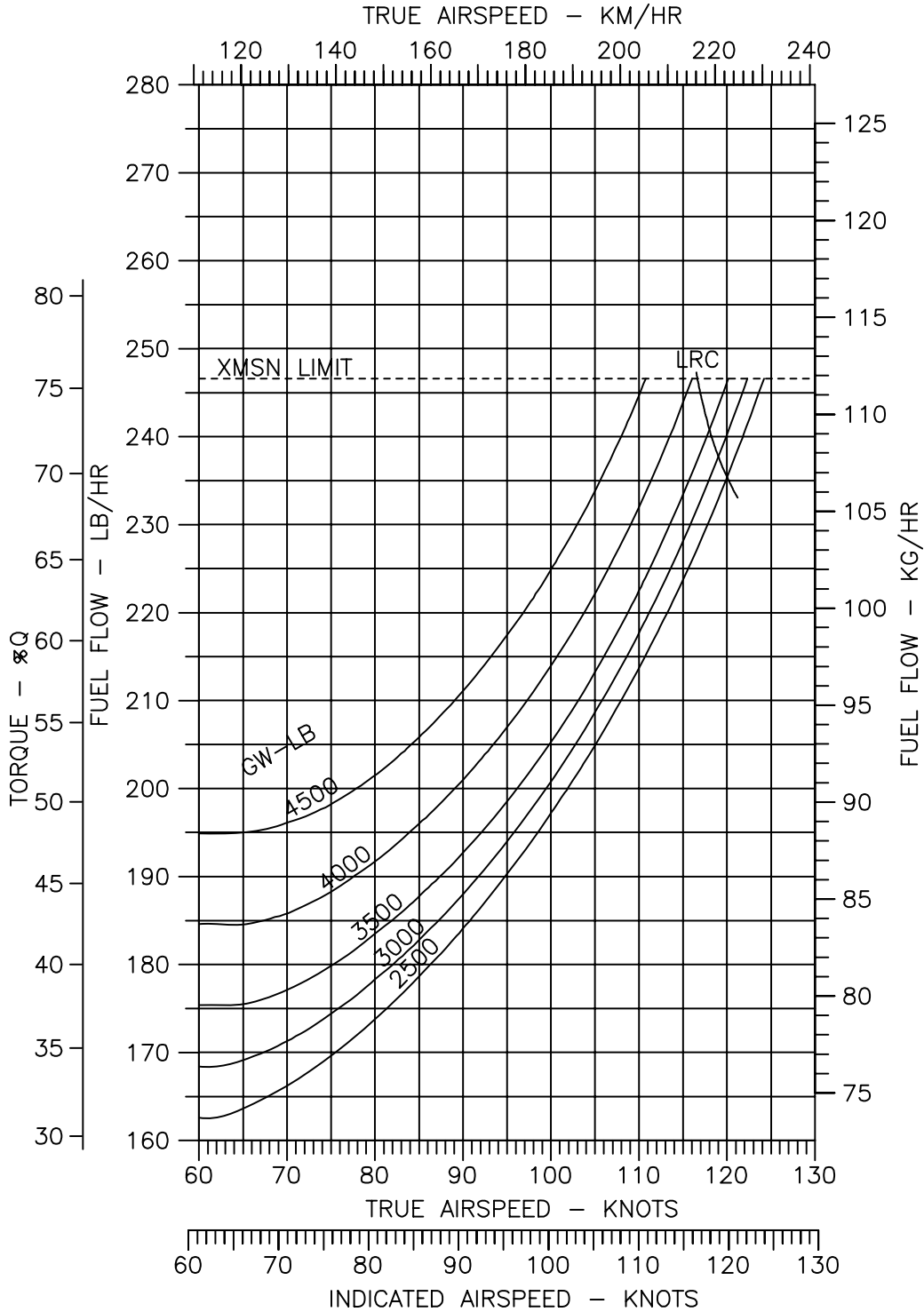

THE DATA SET FORTH ON THIS DOCUMENT ARE GENERAL IN NATURE AND MAY VARY WITH CONDITIONS. FOR PERFORMANCE DATA AND OPERATING LIMITATIONS FOR ANY SPECIFIC FLIGHT MISSION, REFERENCE MUST BE MADE TO THE APPROVED FLIGHT MANUAL.



**FUEL FLOW VERSUS AIRSPEED
PRESSURE ALTITUDE = 6000 FEET
OAT = + 3 DEG C**

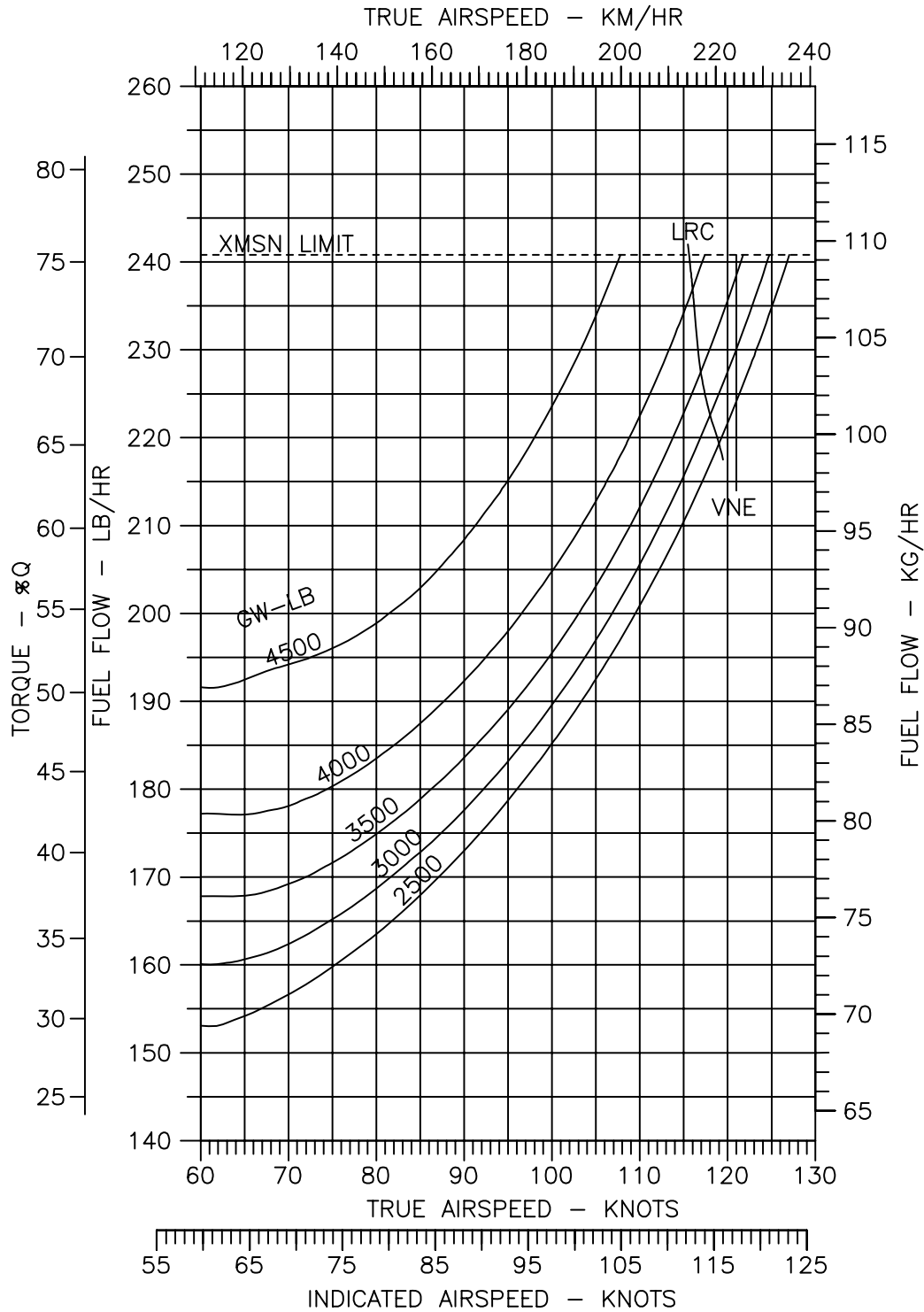

THE DATA SET FORTH ON THIS DOCUMENT ARE GENERAL IN NATURE AND MAY VARY WITH CONDITIONS. FOR PERFORMANCE DATA AND OPERATING LIMITATIONS FOR ANY SPECIFIC FLIGHT MISSION, REFERENCE MUST BE MADE TO THE APPROVED FLIGHT MANUAL.

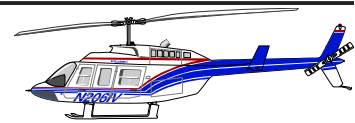

**FUEL FLOW VERSUS AIRSPEED
PRESSURE ALTITUDE = 8000 FEET
OAT = -1 DEG C**

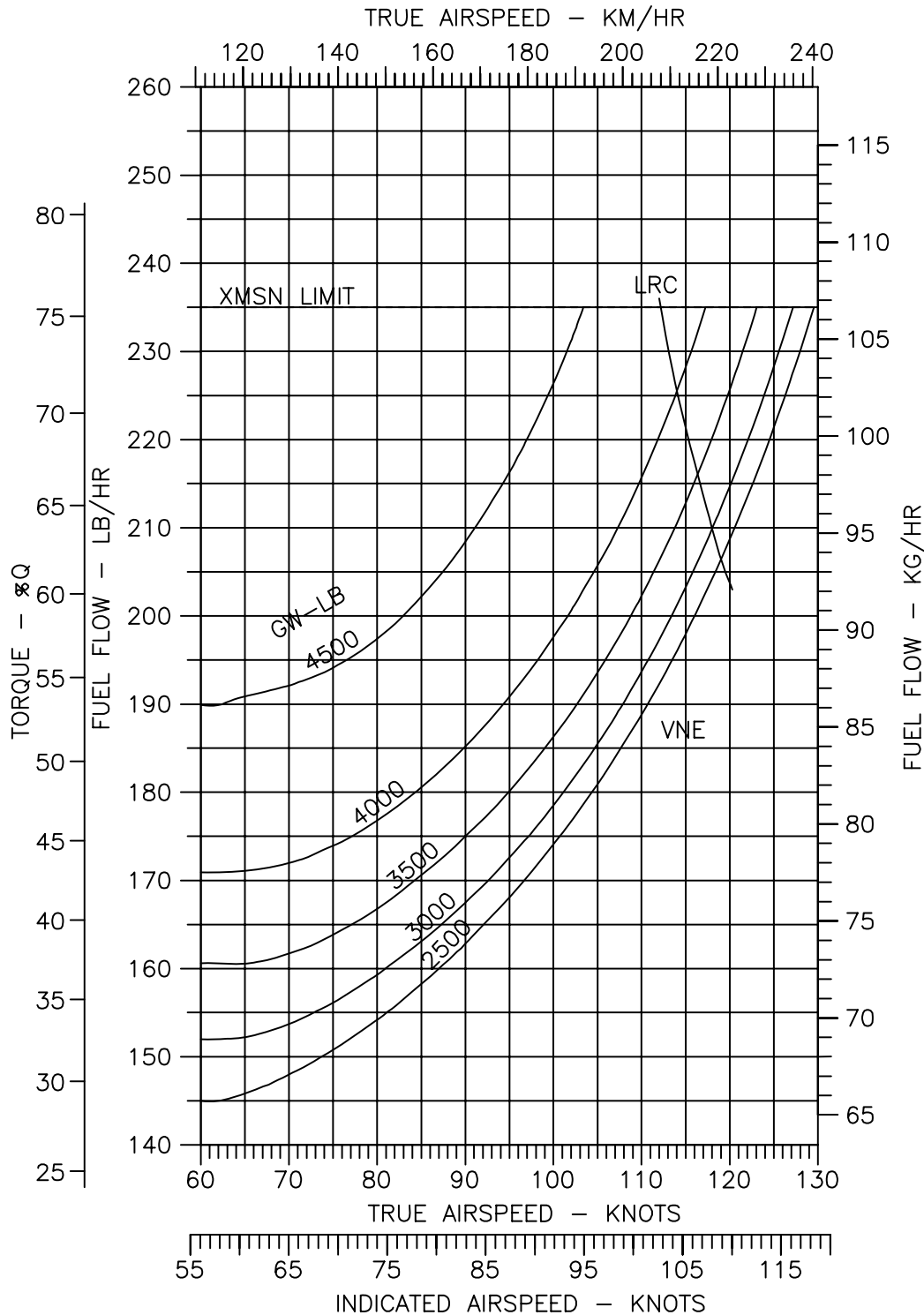

THE DATA SET FORTH ON THIS DOCUMENT ARE GENERAL IN NATURE AND MAY VARY WITH CONDITIONS. FOR PERFORMANCE DATA AND OPERATING LIMITATIONS FOR ANY SPECIFIC FLIGHT MISSION, REFERENCE MUST BE MADE TO THE APPROVED FLIGHT MANUAL.



**FUEL FLOW VERSUS AIRSPEED
PRESSURE ALTITUDE = SEA LEVEL
OAT = + 35 DEG C**

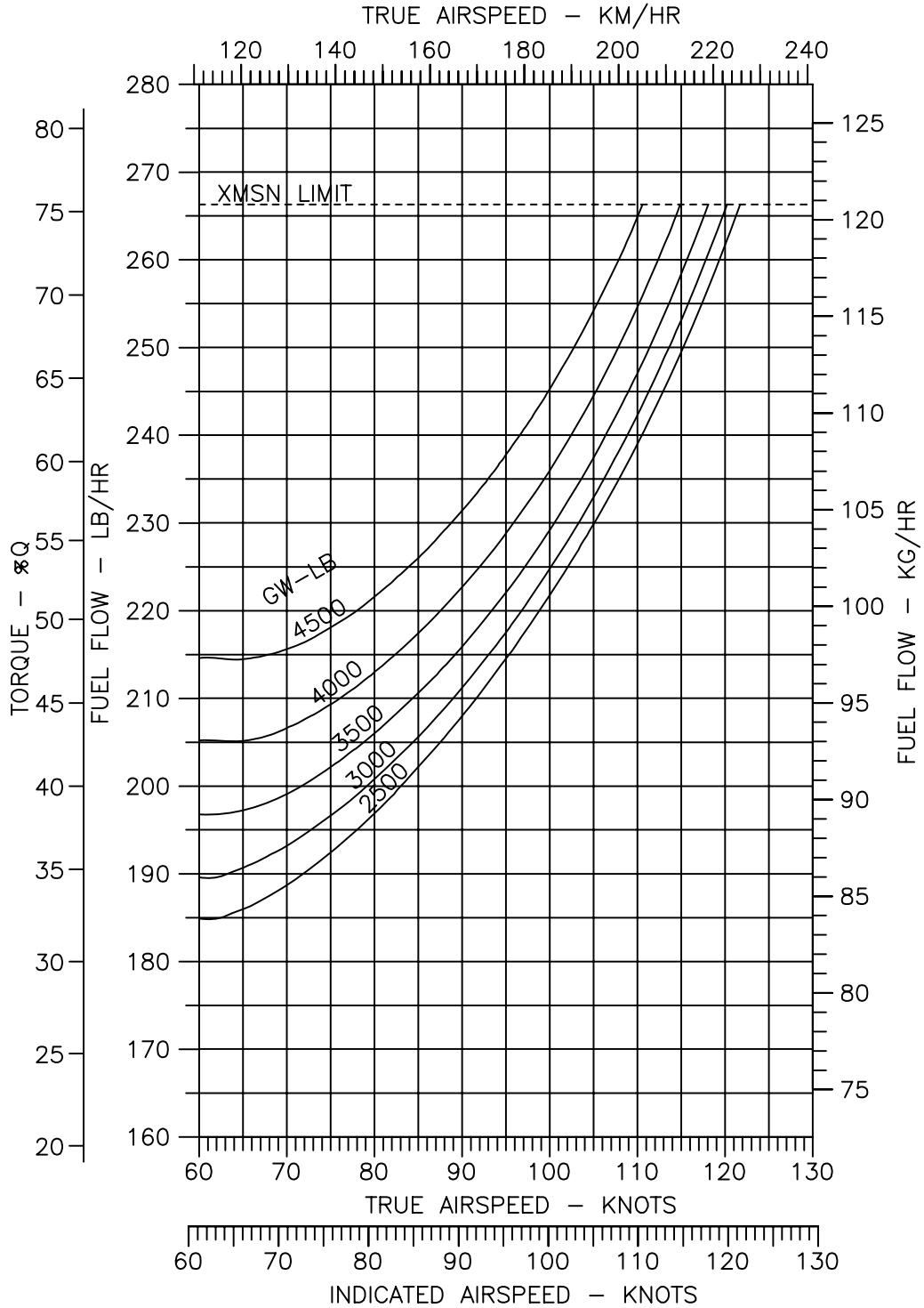

THE DATA SET FORTH ON THIS DOCUMENT ARE GENERAL IN NATURE AND MAY VARY WITH CONDITIONS. FOR PERFORMANCE DATA AND OPERATING LIMITATIONS FOR ANY SPECIFIC FLIGHT MISSION, REFERENCE MUST BE MADE TO THE APPROVED FLIGHT MANUAL.

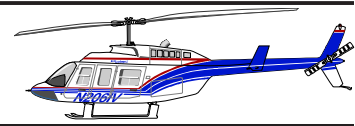

**FUEL FLOW VERSUS AIRSPEED
PRESSURE ALTITUDE = 2000 FEET
OAT = + 31 DEG C**

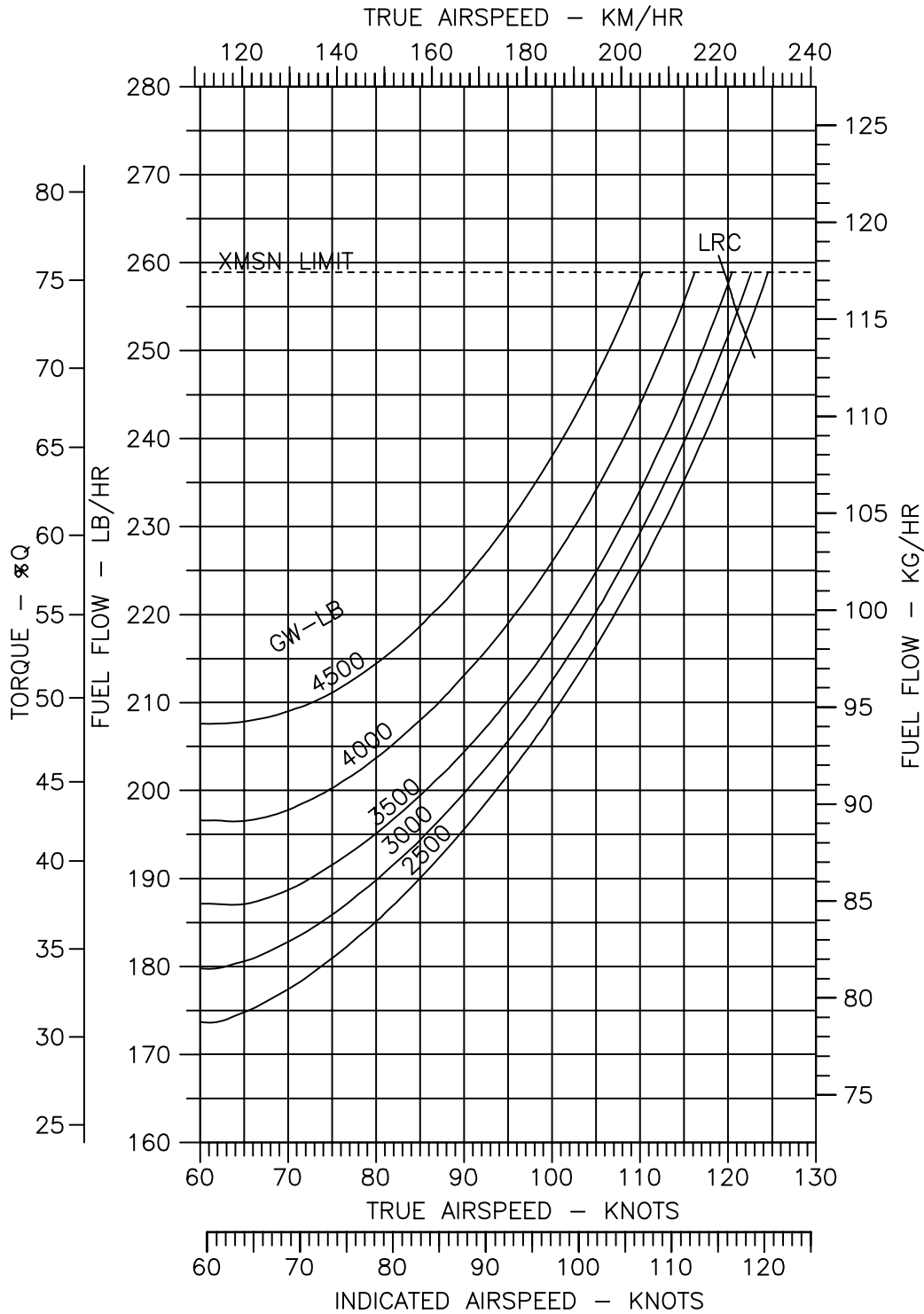

THE DATA SET FORTH ON THIS DOCUMENT ARE GENERAL IN NATURE AND MAY VARY WITH CONDITIONS. FOR PERFORMANCE DATA AND OPERATING LIMITATIONS FOR ANY SPECIFIC FLIGHT MISSION, REFERENCE MUST BE MADE TO THE APPROVED FLIGHT MANUAL.



**FUEL FLOW VERSUS AIRSPEED
PRESSURE ALTITUDE = 4000 FEET
OAT = + 27 DEG C**

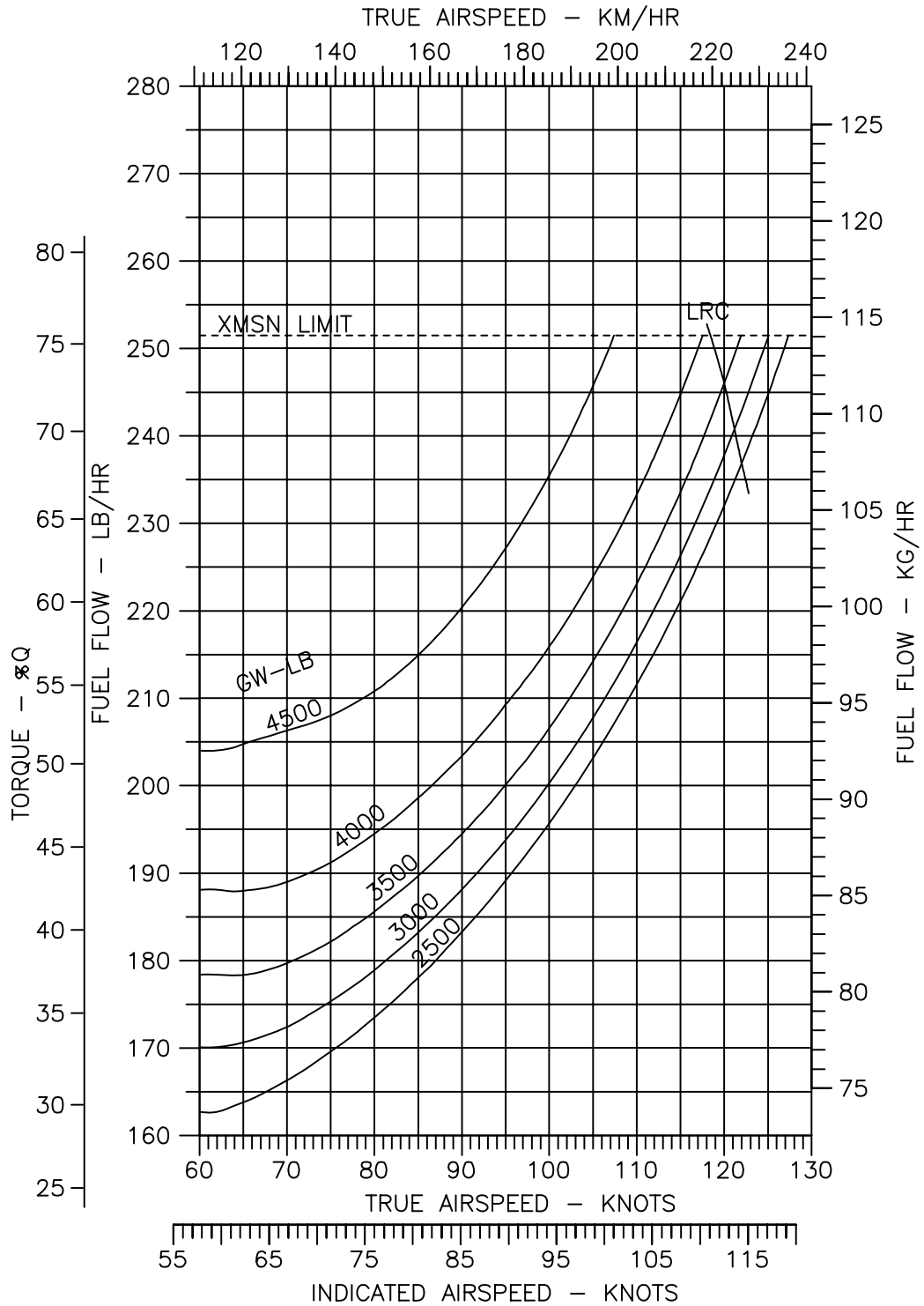

THE DATA SET FORTH ON THIS DOCUMENT ARE GENERAL IN NATURE AND MAY VARY WITH CONDITIONS. FOR PERFORMANCE DATA AND OPERATING LIMITATIONS FOR ANY SPECIFIC FLIGHT MISSION, REFERENCE MUST BE MADE TO THE APPROVED FLIGHT MANUAL.

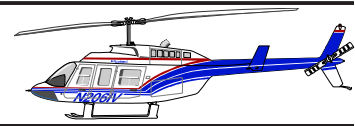

FUEL FLOW VERSUS AIRSPEED PRESSURE ALTITUDE = 6000 FEET OAT = + 23 DEG C

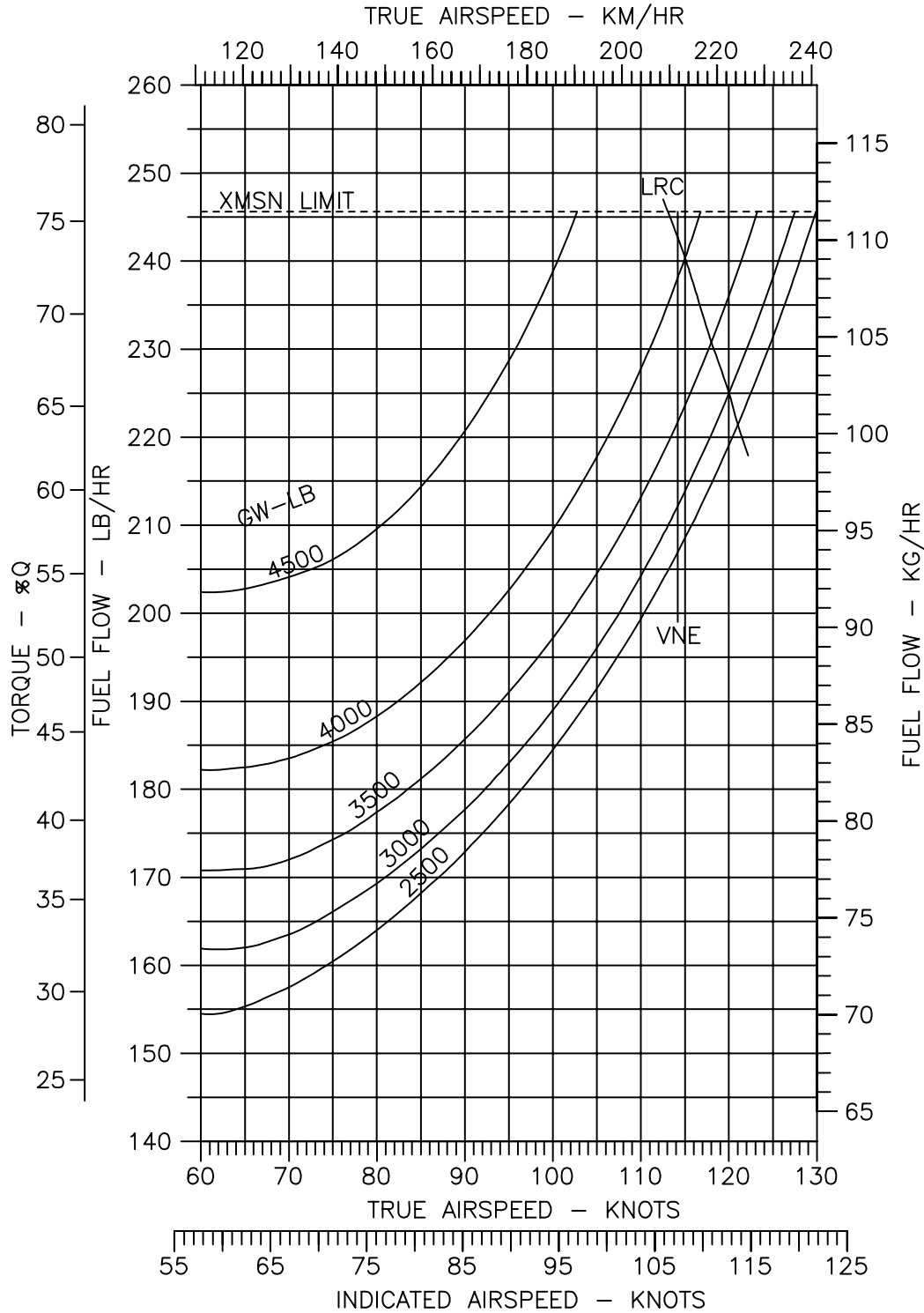

THE DATA SET FORTH ON THIS DOCUMENT ARE GENERAL IN NATURE AND MAY VARY WITH CONDITIONS. FOR PERFORMANCE DATA AND OPERATING LIMITATIONS FOR ANY SPECIFIC FLIGHT MISSION, REFERENCE MUST BE MADE TO THE APPROVED FLIGHT MANUAL.

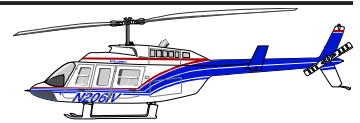

**FUEL FLOW VERSUS AIRSPEED
PRESSURE ALTITUDE = 8000 FEET
OAT = +19 DEG C**

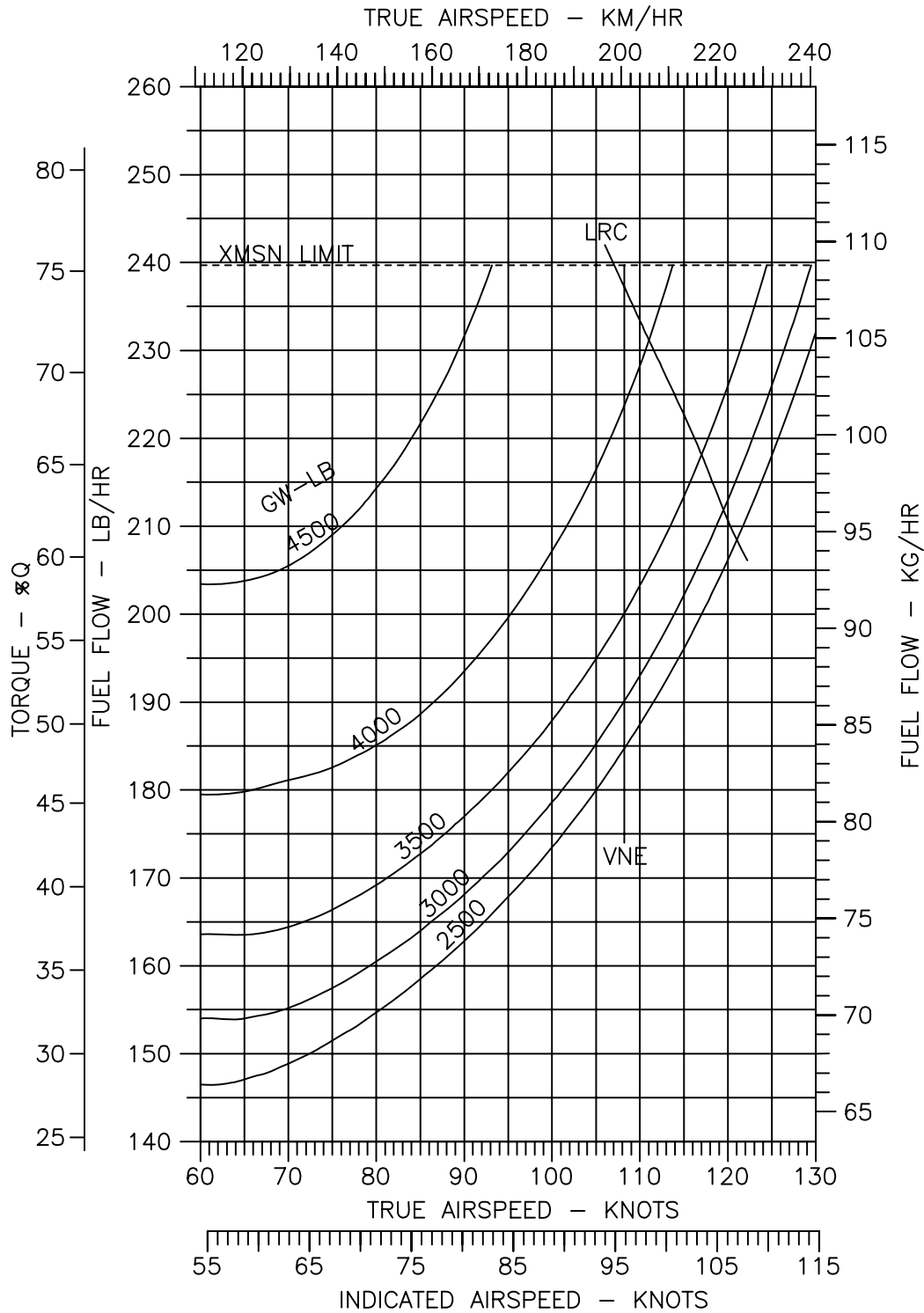

THE DATA SET FORTH ON THIS DOCUMENT ARE GENERAL IN NATURE AND MAY VARY WITH CONDITIONS. FOR PERFORMANCE DATA AND OPERATING LIMITATIONS FOR ANY SPECIFIC FLIGHT MISSION, REFERENCE MUST BE MADE TO THE APPROVED FLIGHT MANUAL.



COST OF OPERATIONS

INTRODUCTION

Bell Helicopter Textron's cost of operations data for current production helicopters is based on information from Bell operators and service facilities.

BHT's Product Support organization accumulates cost data from a diverse group of operators - large, small; sub-polar, subtropical; inland, coastal; corporate, charter. This information is analyzed to generate sample data for each production model which are averages of the field experience.

BHT intends to continue monitoring actual costs to enable annual updates of the data to maintain its currency.

The following discussion is provided to review the variables involved in the helicopter's direct and indirect cost of operations as well as its cost of ownership.

The total cost of helicopter ownership and operation involves both direct and indirect costs. The direct costs are those which are incurred essentially by the flight hour and include:

- Fuel, Lubricants
- Basic Airframe Maintenance
- Powerplant Maintenance

The indirect costs are not directly dependent upon the number of hours flown and include:

- Insurance
- Facilities (hangar, workshop, etc.)
- Crew Compensation
- Financial Factors (depreciation, investment tax credit, financing costs, etc.)

Sample direct operating cost data is available for each current production model. Detailed estimates for total costs relating to specific operations are available through the BHT regional marketing manager or corporate office using input data supplied by customer/prospect.

DIRECT COSTS

Fuel, Lubricants

A typical average value of fuel and lubricant costs is included in the sample data provided for each model.

Fuel consumption depends upon speed, temperature, externally-mounted accessories, sling loads, etc. A band of approximately 10% more or less than sample value will cover these factors for normal operations.

Fuel pricing varies considerably based on where the fuel is purchased geographically and whether it is purchased retail or in bulk. The sample cases use average retail purchase price prevalent at the time of the sample data are prepared.

Basic Airframe Maintenance

Airframe maintenance is divided into four categories:

- Periodic Inspections
- Overhauls
- Replacement of Retirement Parts
- Unscheduled

Periodic inspections include those inspection tasks, with their part requirements, listed in the Maintenance Manual for each model.

Man hours for periodic inspections can vary from the sample value provided because of differences in personal experience, tool and parts availability, facilities, environmental effects such as extremes in working temperatures. Man hour costs/hour are also variable among the Authorized Service Centers as a result of differences in local costs, overhead expenses and volume of work. The sample value is an average of costs per hour at Authorized Service Centers at the time of publication.

Overhauls include removal, disassembly, inspection, parts replacement, reassembly and reinstallation of certain components/assemblies at the periods stated in the BHT Maintenance Manual.

Overhaul man hour and parts requirements are subject to considerable variation depending upon the helicopter's operations and environments. The sample data reflect average values.

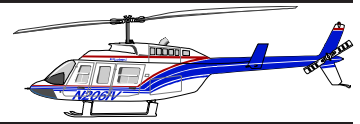

COST OF OPERATIONS (continued)

Retirement parts are those which are subject to disposal after an operating time stated in the Maintenance Manual. These are normally components of the rotors/control systems which are subject to oscillatory loads and are designed and tested for use over a finite number of flight hours rather than on their condition. The replacement at the required intervals requires some labor which is included in the man hour data in the sample.

Unscheduled maintenance encompasses labor and parts replacement for major maintenance not covered under the formal Maintenance Manual requirements for inspections and overhauls. It also includes those additional maintenance requirements imposed by the manufacturer through issue of Service Bulletins.

The sample data for periodic inspections provide for some minor unscheduled maintenance tasks resulting from the inspection.

Powerplant Maintenance

The powerplant (engine [s]) requires periodic inspection and overhauls. The overhaul periods are based on the number of operating hours or on the number of cycles, whichever is the first limit to be attained. Start cycles are a factor because thermal cycles are important in the design of the turbine engine's rotating components. Overhauls are performed by the engine manufacturer and/or at authorized facilities.

Powerplant overhaul can be performed for the engine as a unit, or in some cases for individual modules. (Modules can be gearbox, compressor, turbine, for example.) Each module can have its own overhaul period. Modular overhaul can be cost-effective for some operations and it use should be evaluated.

Engine or module exchanges can be made in lieu of overhaul. For details, contact the engine manufacturer or his authorized distributors/service centers. The sample costs are based on an average exchange.

The powerplant may also require unscheduled maintenance (unscheduled removals for repair, parts replacement).

INDIRECT COSTS

Insurance

Insurance rates are based on a number of factors including claim experience, type of operations, and crew qualifications. Rates can be obtained from insurance agent/broker.

Facilities

Facilities can include hangar, workshop, parts storage area, tools, ground support equipment and administrative area as appropriate to the specific operation.

Crew Compensation

The number of aircrew personnel depends on the individual operation; i. e., whether the normal crew consists of one or two pilots, hours per day flown, backup requirements for illness, vacation, etc.

Bell regional marketing managers can advise typical local costs for estimation purposes.

Financial Factors

Funding a helicopter purchase can be accomplished in a variety of ways, including cash, short term note, long term note, partnership, etc. For investment accounting, several depreciation methods also exist; straight line, double declining, sum of the years digits, etc. Value of resale is a significant factor.

Miscellaneous Factors

Staff expenses (other than aircrew and direct maintenance personnel), utilities, office expenses, etc.

OWNERSHIP ANALYSIS PROGRAM

Bell Helicopter Textron uses the **Life Cycle Cost 2006** computer program provided by **Conklin & de Decker Associates, Inc.** to determine ownership costs for an operators planned period of utilization for the aircraft. Conklin's Rotorcraft Analysis Office may be contacted at: Phone; (817)277-6403 or Fax; (817)277-6402.

Bell's regional marketing managers or corporate office personnel will be able to assist in preparing an ownership analysis which is customized for our customers specific individual conditions and needs.



SAMPLE - COST OF OPERATIONS
U S DOLLARS PER FLIGHT HOUR

		<u>Operator Overhaul</u>
<u>Fuel and Lubricants</u>		
Fuel: (Note 1) [38Gal/Hr]		\$85.50
Lubricants: 3% of Fuel Cost		2.57
<u>Airframe Direct Maintenance</u>		
Labor: (Note 2)		
Inspection	(0.331 MH/FH)	21.50
Overhaul	(0.094 MH/FH)	6.08
Unscheduled and on-condition	(0.349 MH/FH)	22.69
Parts:		
Inspections		1.17
Retirement		52.47
Overhaul		20.66
Unscheduled and on-condition		58.97
<u>Powerplant Direct Maintenance</u>		
Overhaul (Including Accessories- Note 3)		56.80
Line Maintenance (labor)	(0.067 MH/FH)	4.33
<u>TOTAL AVERAGE COST / HR</u>		<u>\$332.74</u>

Note 1: Fuel at \$2.25 per gallon. Average fuel consumption for LRC at 1000 feet, ISA, (Jet-A at 6.8 Lb/Gal.)

Note 2: Labor rate assumed at \$65.00 per hour.

Note 3: Includes all scheduled and unscheduled maintenance and life limited parts replacement assuming normal operating environment.

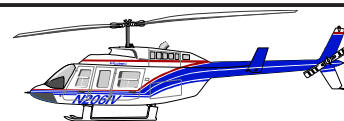

LIMITED LIFE COMPONENTS

<u>PART NUMBER</u>	<u>COMPONENT</u>	<u>LIFE IN FLIGHT HOURS</u>	<u>LIFE IN (RIN)</u>	<u>QTY PER A/C</u>	<u>LIST PRICE (EA)</u>	<u>TOTAL COST (FLT HR)</u>
<u>MAIN ROTOR HUB AND BLADES</u>						
206-011-120-103	Trunnion	2,400	24,000	1	2,873	\$ 1.20
206-011-150-105	Strap Fitting	2,400		2	1,718	\$ 1.43
206-011-125-001	Strap Pin	1,200		2	265	\$ 0.44
206-011-132-113A	Grip	4,800		2	7,627	\$ 3.18
206-011-154-107	Tension-Torsion Strap	1,200		2	3,662	\$ 6.10
206-011-260-101	Latch Bolt	1,200		2	656	\$ 1.09
206-015-001-115	Main Rotor Blade	3,600		2	34,362	\$ 19.09

MAIN ROTOR MAST

206-040-535-109	Main Rotor Mast	5,000	44,000	1	13,299	\$ 2.66
-----------------	-----------------	-------	--------	---	--------	---------

MAIN ROTOR CONTROLS

206-001-193-001	Cyclic Tube	4,800		2	1,819	\$ 0.76
-----------------	-------------	-------	--	---	-------	---------

SWASHPLATE AND SUPPORT

206-010-446-107	Collective Idler Link	4,800		1	4,046	\$ 0.84
206-010-445-113	Swashplate Support	4,800		1	8,779	\$ 1.83
206-010-454-109	Collective Sleeve	4,800		1	3,573	\$ 0.74
206-010-447-109	Collective Lever	4,800		1	7,514	\$ 1.57

POWERTRAIN

206-340-300-105	Kaflex Input Driveshaft	5,000		1	31,490	\$ 6.30
-----------------	-------------------------	-------	--	---	--------	---------

TAIL ROTOR HUB AND BLADES

206-011-819-109	Tail Rotor Yoke	5,000		1	4,811	\$ 0.96
206-016-201-131	Tail Rotor Blade	2,500		2	5,965	\$ 4.77

TAIL ROTOR GEARBOX

206-040-410-101	Duplex Bearing	3,000		1	1,506	\$ 0.50
-----------------	----------------	-------	--	---	-------	---------

TOTAL

\$53.47

COMPONENT OVERHAUL INTERVALS (HOURS)

M/R Hub	2,400	Freewheeling Assy	3,000	T/R Hub	2,500
Mast Assy	3,000	Swashplate & Support	4,800	K-Flex Drive Shaft	1,250
Transmission	4,500	T/R Gearbox	6,000	Hyd Pump/Resv & Servos	3,600
		T/R Drive System	3,000/3 yrs		

Prices and hours are subject to change without notice.

THESE DATA ARE PROVIDED FOR ILLUSTRATION PURPOSES. CONSULT MAINTENANCE DOCUMENTS AND BHT SPARE PARTS PRICING FOR CURRENT, OFFICIAL INFORMATION.

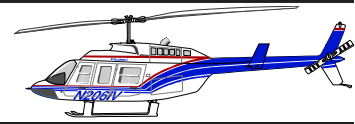

**Sample Illustrations of the
Standard Paint Schemes
are available from your
Bell Helicopter Sales Representative**

PAINT SELECTION NOTES:

- 1. COLOR RENDERINGS (ORIGINAL) MUST BE PROVIDED FOR ANY DEVIATION TO THE STANDARD SCHEMES (ALL MODELS).**
- 2. CUSTOM PAINT SCHEMES TO CUSTOMER SPECIFICATION ARE AVAILABLE, AND A PRICE QUOTE WILL BE PROVIDED ON REQUEST. PLEASE PROVIDE AS MUCH DETAIL AS POSSIBLE WHEN DESCRIBING SPECIAL INSTRUCTIONS AND CUSTOM PAINT SCHEMES.**
- 3. THE DANGER ARROW IS ALWAYS APPLIED ON THE TAIL BOOM BETWEEN THE HORIZONTAL STABILIZER AND THE TAIL ROTOR, NOT WITHSTANDING ANY OTHER ILLUSTRATIONS.**
- 4. UNLESS CLEARLY SPECIFIED (LOCATION, DIMENSION, COLOR), REGISTRATION MARKINGS WILL BE APPLIED PER FAA REGULATIONS (ALL MODELS).**
- 5. METALLIC PAINT CAN NOT BE APPLIED OVER RADOME AREAS WHEN A RADAR IS INSTALLED.**
- 6. PLACEMENT OF BELL MODEL LOGOS IS EFFECTED BY INDIVIDUAL PAINT SCHEMES, AND WILL BE APPLIED AT THE DISCRETION OF BELL HELICOPTER UNLESS OTHERWISE SPECIFIED BY THE CUSTOMER.**

For additional information visit the Bell Helicopter Textron Website

Homepage: www.bellhelicopter.com

BELL HELICOPTER TEXTRON INC.

Sales Contact Telephone Numbers

Sales Inquiries

U.S. Toll Free: 1-800-FLY-BELL

International/US: 817-280-2800

Email: marketing@bellhelicopter.textron.com

Regional Sales Areas

US/Canada 817-280-6789

Asia Pacific 817-280-2197

Europe/Middle East/Africa 817-280-3261

Latin America 817-280-2879

Used Helicopter Sales / www.BellNetX.com 817-280-2147

Fax: 817-280-8802

Customer Center

Ft. Worth / Alliance Airport Facility

P. O. Box 482

Ft. Worth, TX 76101-0482

817-280-6187 Fax: 817-280-8802

marketing@bellhelicopter.textron.com

Manufacturing Facility

Bell Helicopter Textron Canada Limited

12,800 rue de l'Avenir

Mirabel, Quebec

Canada J7J 1R4

450-437-3400 Fax: 450-437-2006

This book was produced by



Visual Communications Center

P. O. Box 482

Ft. Worth, TX 76101-0482



P.O. Box 482, Fort Worth, Texas 76101,
Phone: (817) 280-2800, Fax: (817) 278-8802
www.bellhelicopter.textron.com

BELL HELICOPTER TEXTRON CANADA LIMITED
12,800 rue de l' Avenir
Mirabel, Quebec, Canada J7J1R4
Phone: (450) 437-3400 Fax: (450) 437-2006

The data set forth in this brochure are general in nature and may vary with conditions. For performance data and operating limitations for any specific flight mission reference must be made to the approved flight manual.

Written, Edited and Layout by:
Dave Wyatt
817-280-6918
E-Mail Address: dwyatt@bellhelicopter.textron.com

© 2006 Bell Helicopter Textron Inc.
All Rights Reserved.
Printed in USA
January 2006